

Installer instructions

Remove this section on completion of the installation and leave the balance of the pages with the cover with the end user.

Revision May 2007

Please note the following changes to the previous revision May 2005.

1. Increased receiver memory 25 locations for open/close BT and 6 locations for courtesy light L control
2. Added hands free master erase of receiver memory option. For when the plug point is across the garage from the unit and out of reach.
3. Power fail indication: Buzzer beeps twice before opening.
4. Power failure will also disable the courtesy light relay to conserve battery power.

Please note the following changes to the previous revision May 2006.

1. Batteries are incorporated into the motor-head of this model.
2. Control card layout has been redesigned to include the battery charger.
3. Drawbar to motor-head attachment now indicates the use of the M8 black machine bolts and the mounting straps are shown in the correct position.

NB. Never run the motor head without the drawbar attached or move the bobbin position along the drawbar without the motor head attached. The internal limit switch assembly has been synchronized to the drawbar ex factory.



1. While aligning the splined shaft and socket, gently press the motor head and drawbar together. Use the packaging to rest the motor head on while doing this so as not to damage the motor head cover.
2. Swing the drawbar so that it lies evenly between the fastening points as above.
3. Fasten the mounting straps down using the 4 x Black M8 machine bolts supplied. Take care not to over tighten, as this will strip the brass inserts out of their moldings.

Mounting hanging angle bracket to drawbar



Trackless tip up type door automation

275mm above the door when closed

To clear the highest point of travel

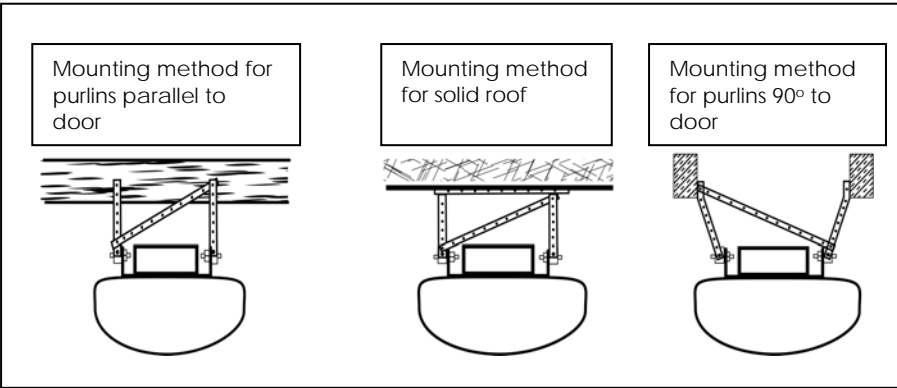
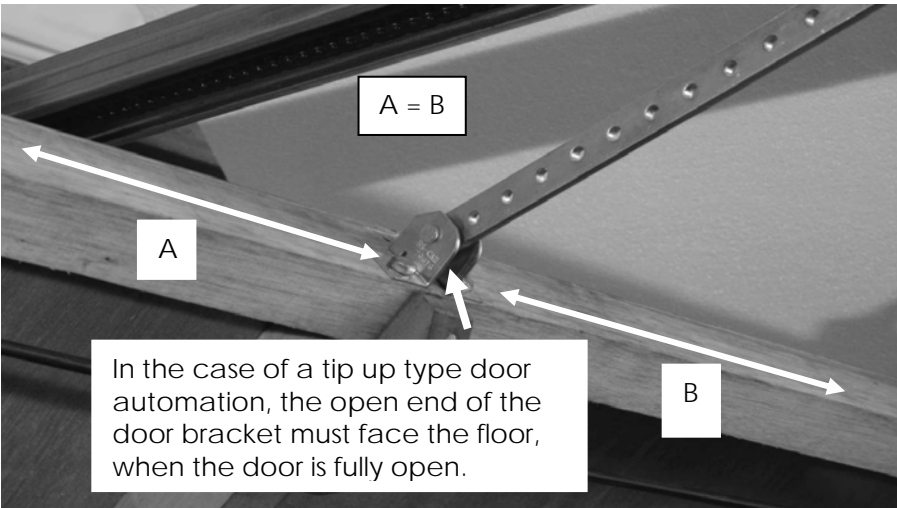
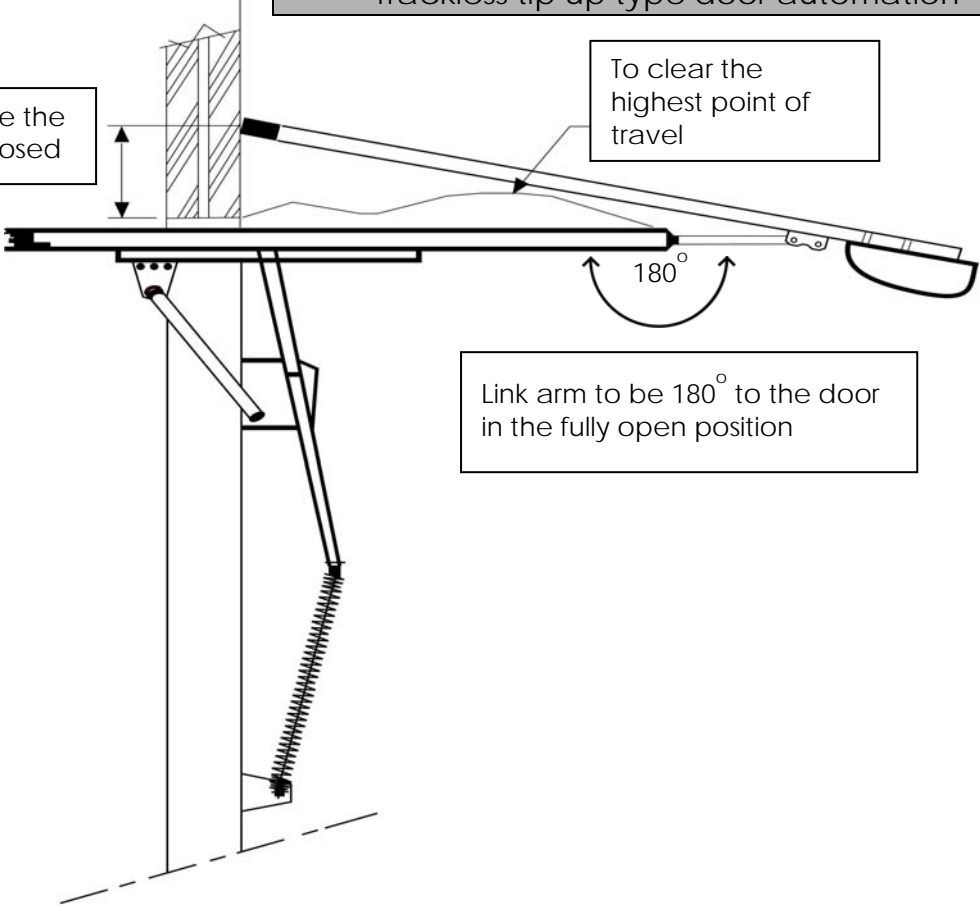

Remove these installer pages and issue the balance to the end user as a user guide.

Overhead sectional door type automation

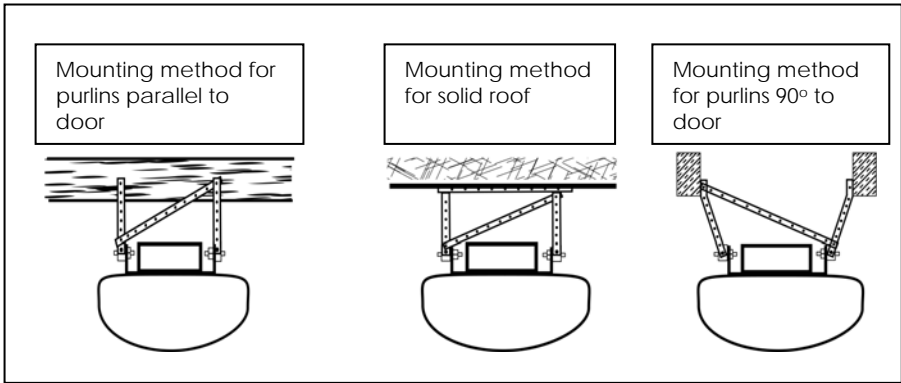
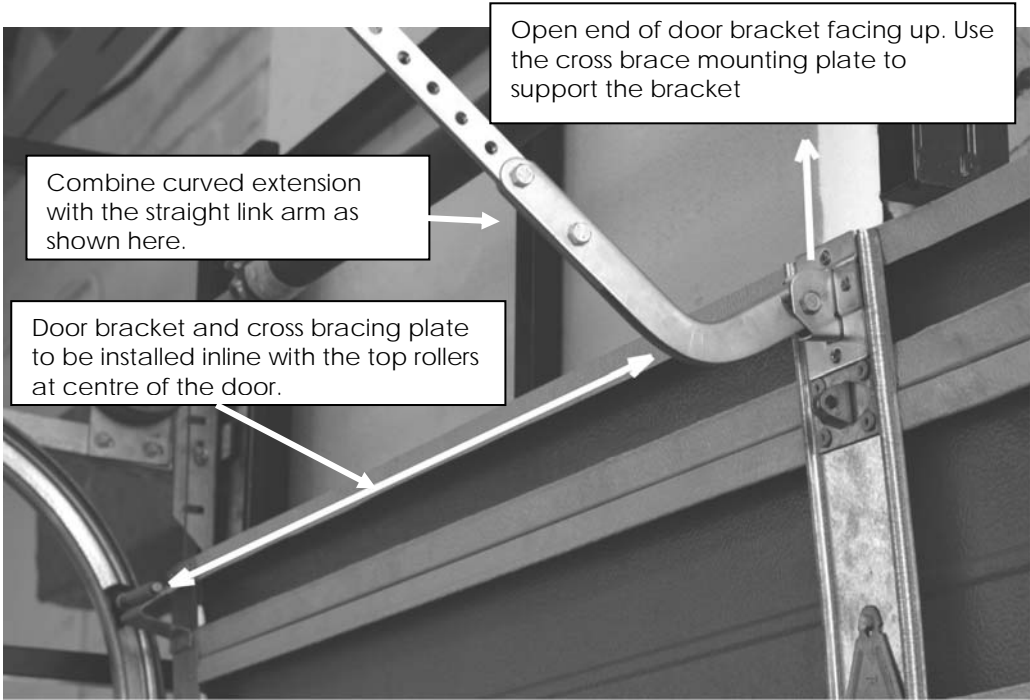
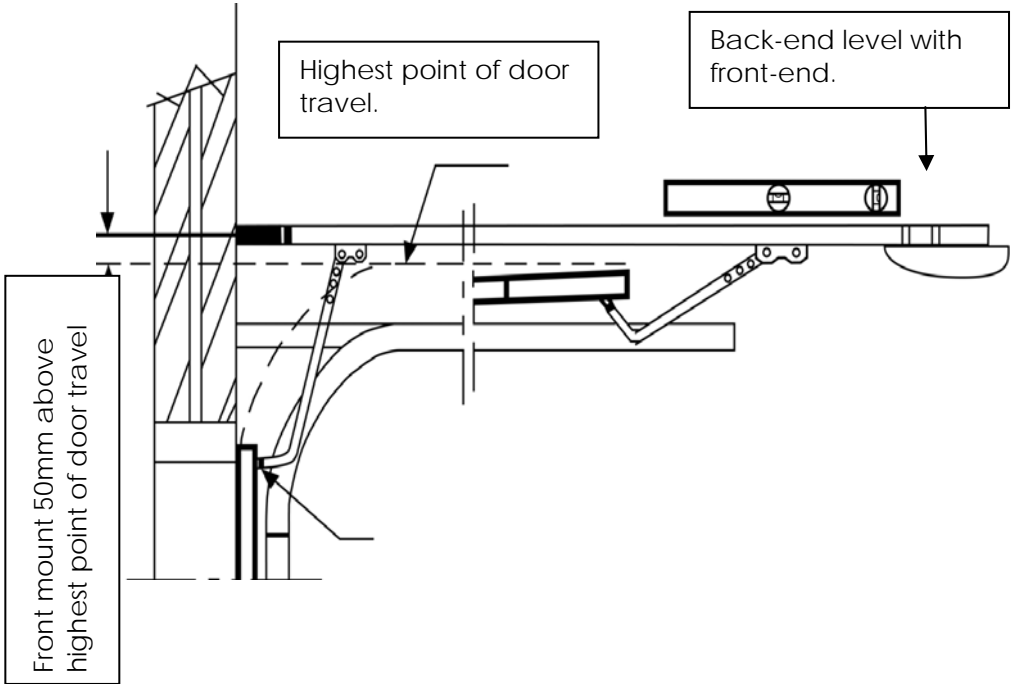

Remove these installer pages and issue the balance to the end user as a user guide.

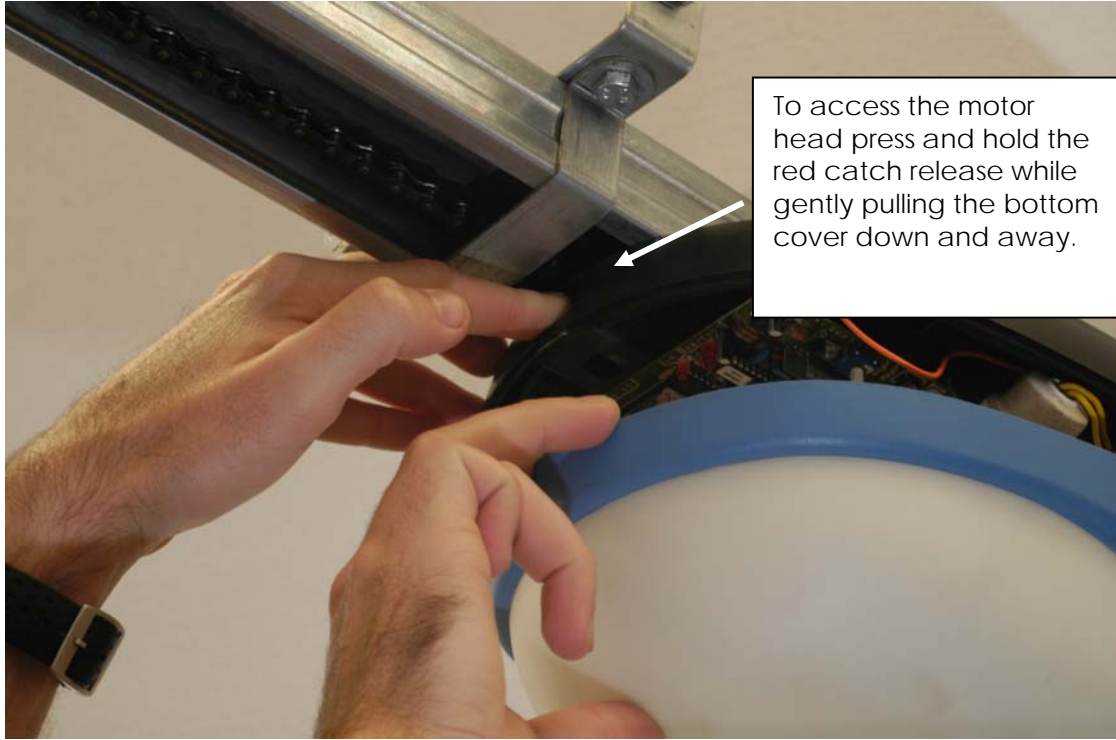

To access the motor head press and hold the red catch release while gently pulling the bottom cover down and away.

Electronic wiring and programming

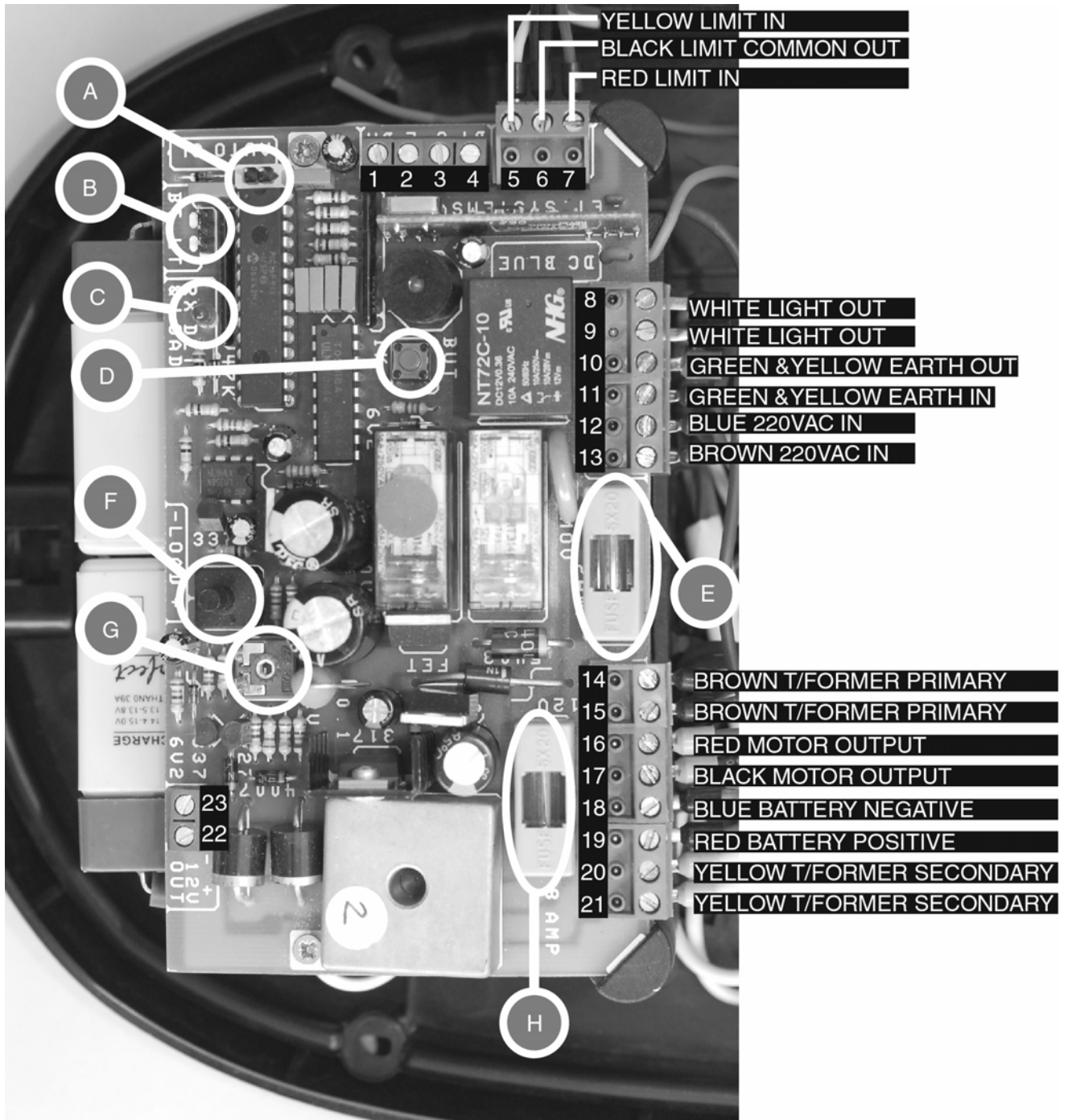

Remove these installer pages and issue the balance to the end user as a user guide.

The colouring of the factory fitted wiring is highlighted here

1. N/O Safety beams input (BM)
2. N/O Courtesy light input (L)
3. Common output (C)
4. N/O Button trigger input (BT)
5. YELLOW - N/O Closed limit input (LC)
6. BLACK - Limit switch common output (C)
7. RED - N/O Open limit input (LO)
8. WHITE - 220Vac Courtesy light output (LMP)
9. WHITE - 220Vac Courtesy light output (LMP)
10. GREEN & YELLOW - Motor and transformer earth (E)
11. GREEN & YELLOW - Household earth (E)
12. BLUE - 220Vac Neutral input (N)
13. BROWN - 220Vac Live input (L)
14. BROWN - 220Vac output to transformer primary (PRI)
15. BROWN - 220Vac output to transformer primary (PRI)
16. RED - 24Vdc motor output (MOT)
17. BLACK - 24Vdc motor output (MOT)
18. BLUE - Batteries negative (BAT)
19. RED - Batteries positive (+)
20. YELLOW - 24Vac input from transformer secondary (SEC)
21. YELLOW - 24Vac input from transformer secondary (SEC)
22. 12V positive auxiliary output (+ 12V OUT)
23. 12V negative auxiliary output (- 12V OUT)

A. **Auto-close link:** Placing a jumper across these 2 pins will cause the door to close automatically after 20sec. from any open position. Before closing the unit will emit three warning beeps. The door still be triggered to close manually before 20sec. has counted down.

B. **Receiver programming pins:** Max BT (Button trigger) = 25 locations.
Max L (Light) = 6 locations.

To master erase: (It is recommended that this be done on first time set up)

1. Remove all power.
2. Short middle and BT receiver pins and place a wire short between terminal 3 and 4 (C + BT) of connector block(or press and hold test button "D")
3. Re-apply power. Buzzer will begin 1 second beeps.
4. When buzzer emits 1 continuous tone remove shorts and power.
5. Re-apply all power.

Programming new Transmitters into memory

1. Press and hold required TX button.
 2. While holding the TX button short the middle pin to the required function pin (BT or L)
 3. When buzzer beeps release TX button and remove short.
 - 1 x Beep - First TX in memory for that function.
 - 2 x Beep – There is still memory available for this function.
 - 10 x Beeps – The last memory location for this function has been filled. Collect all TX's used for this function and check that they are all still working. The last TX learned into this function may have been erased to allow your new TX.
 4. Repeat 1 to 3 above for further TX's.
- C. **RX detection L.E.D.** This will flicker whenever there is a Keeloq transmission present.
- D. **Test Button:** Will operate door as though using a remote button.
- E. **AC supply Fuse:** If blown replace with a 2A fast blow fuse only.
- F. **Load sensing P.O.T:** Used to adjust the amount of obstruction sensitivity necessary, to initiate the automatic safety routine.
When closing, the door will stop and reverse on sensing an obstruction and on opening the door, will stop and wait for the next trigger to reverse. Turn clockwise to make the operator less sensitive to obstructions.
- G. **Charger Voltage P.O.T:** This has been set in the factory to 27.2Volts without battery load. Do not adjust unless qualified to do so.
- H. **Motor output fuse:** If blown replace with an 8A fast blow fuse only. This fuse will blow if the maximum acceptable load is exceeded.

You are now ready to adjust the limit switch positions

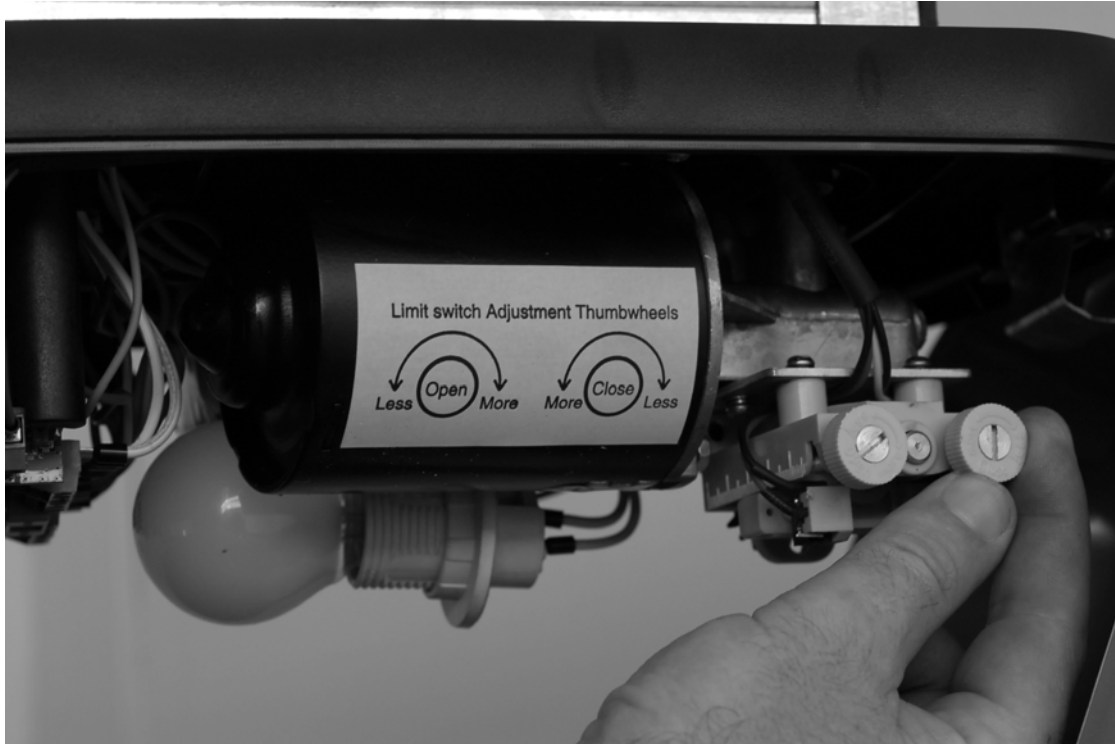

1. **Setting closed limit:** If the door stops short of the fully closed position turn the closed limit adjustment (on right above) anti-clockwise.
2. If the door closes hard and automatically re-opens (Obstruction sensing) then fine adjust the same thumbwheel clockwise. If the chain hangs excessively out of the drawbar when the door is closed then adjust the closed limit clockwise.
3. **Setting open limit:** If the door stops short of the fully open position, turn the open limit adjustment thumbwheel (on left above) clockwise.
4. If the door reaches the fully open position and stops before activating the open, limit (Obstruction sensing); turn the thumbwheel anti-clockwise.

If the unit is allowed to stop in the open position on obstruction sensing and not the limit switch, mechanical damage can occur. I.e. fibreglass doors being ripped.

Battery wiring

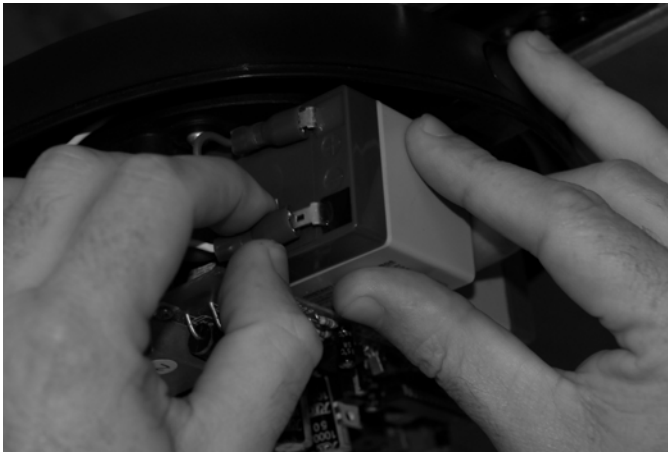

The batteries have been installed in the unit ex-factory. However the "White series link" (A) has been left disconnected from the battery 2 negative terminal. Partially remove battery 2 as explained below. Place the loose "White series link" (A) lug on the negative of this battery. Gently re insert battery until it locks behind the catch.

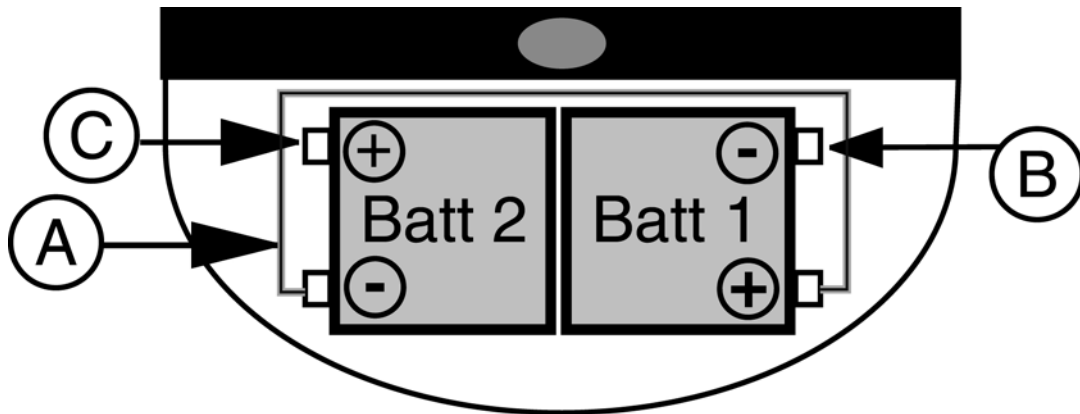

- A. White series link between Battery 2 negative and Battery 1 positive
- B. Connect the "BLUE" battery lead from terminal 18 of the control card here.
- C. Connect the "RED" battery lead from terminal 19 of the control card here.

NOTE THESE BATTERIES ARE CONNECTED IN SERIES. FOR TESTING, MEASURE FOR 24VDC ON TERMINALS B AND C ABOVE WITH THE WHITE WIRE LINK IN PLACE.

How to replace the batteries (Remove mains power before attempting this)



To remove the batteries, press up on the catch and slide the battery out of the holder. Take care to disconnect the battery leads before removing the battery completely.

When inserting the batteries, ensure that the battery terminals face towards the outside of the motor-head. Connect the correct leads onto the correct terminals, as per Battery wiring on the previous page.

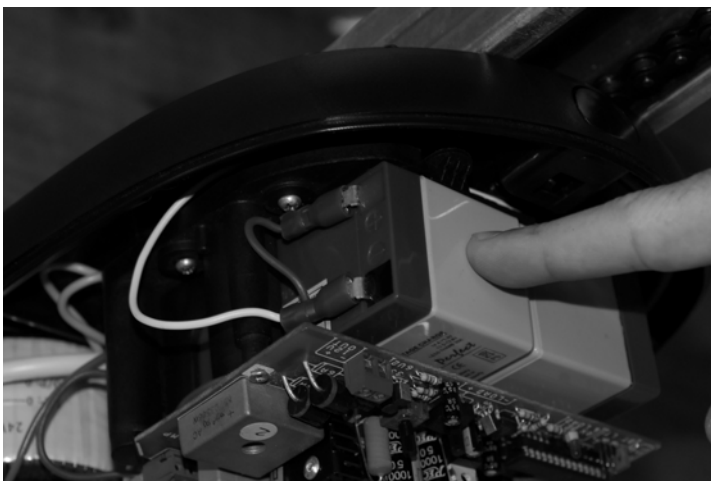

Once the battery leads have been connected gently press on the battery until it locks behind the catch at the top as shown here. Be sure as you do this that the battery leads are clear and do not get caught.

Remove these installer pages and issue the balance to the end user as a user guide.

Important note about the battery back-up!

The available reserve is 1.2A/hour at 24Vdc when fully charged.

In the case of a power failure the DC BLUE PLUS will draw all power from the batteries. This includes the standby current required by the control card.

The unit will, therefore, remain powered for approximately 12-18hrs without running the door (and with no auxiliaries connected) there after the door may not run correctly.

The running time available on the batteries will be dependant on how heavy the door action is and how long the door run time is per full cycle. The heavier the door action or the longer the run time, the more drain on the battery reserve each cycle.

The battery reserve recharge time is approximately 8hrs to full charge on resumption of mains power supply. (Depending on length of standby time used)

NB! Extended power failures will be detrimental to the lifespan of the batteries. To prevent irreversible damage to the batteries re-apply power immediately you become aware of the power interruption. Or leave the unit disconnected until the electrical service provider resumes supply.

Advanced on-board receiver features.

1. **Adding remotes via an existing remote:** This feature allows the installer to guide his client through the adding of remote controls to the Bt (Button trigger) channel without accessing the control card, using a previously programmed remote that has control of the L (light) channel.
 - a. Open door fully,
 - b. Press and hold the remote button that controls the (L) light channel, until the onboard buzzer emits a continuous tone,
 - c. Press and release the button on the new transmitter before the buzzer tone stops. If the tone stops before pressing a transmitter button then restart from (b).
 - d. The on-board buzzer will indicate whether or not the programming was successful by one of the following;
 - i. **No beeps** = unsuccessful – contact supplier.
 - ii. **2 beeps** = successful – repeat steps (a) to (c) for more remote programming.
 - iii. **10 beeps** = successful however the previous remote in memory location has been deleted due to the memory being full. – Contact supplier.

2. **Remote controlled holiday lock-out:** This feature allows for any of the remotes programmed into the L (light) channel to lock-out all use of the unit. i.e. disallow housekeeper from gaining access when the owner is away.
 - a. Close door fully,
 - b. Press and hold the remote button that controls the L (light) channel, until the on-board buzzer emits three rapid beeps.

Any BT (Button trigger) attempt will now result in the on-board buzzer repeating the three rapid beeps.

 - c. To unlock repeat (b) above, this time however the on-board buzzer will emit three long beeps to indicate unlock status