

ET 500

INSTALLERS' MANUAL

(Remove these pages when done and issue the balance of this booklet to the end-user)



1. WHAT'S IN THE BOX	3
A list of contents you will receive with this product and technical specifications	
2. WHAT'S NOT IN THE BOX	5
A list of optional accessories available for this product. Please contact your E.T supplier for more information.	
3. RECOMMENDED TOOLS	6
A list of tools recommended for the installation of this product	
4. IMPORTANT: BEFORE INSTALLING	7
What you need to know before installing this product.	
<ul style="list-style-type: none">— Gate mechanics— Cabling requirements	
<p><u>PLEASE ENSURE THAT YOU READ AND UNDERSTAND THIS SECTION BEFORE INSTALLING THE PRODUCT.</u></p> <p>This section highlights any special warnings and precautions.</p>	
5. INSTALLING THE HARDWARE	10
<ul style="list-style-type: none">— Base plate mounting— Gearbox mounting— Mounting the rack— Mounting and adjusting the limit actuators— Adjusting motor final position	
6. WIRING & SCHEMATICS	15
7. PROGRAMMING & SELECTING MODE OPTIONS	18

IN THE BAG

- 4 x M10 J-bolts
- 8 x M10 machine nuts
- 8 x M10 flat washers
- 4 x M10 nylock nuts
- 1 x adjustable base plate
- 1 x anti-lift bracket
- 2 x M8 nylock nuts
- 2 x M8 square flat washers
- 2 x limit actuators
- 2 x self-tapping screws & guides
- 1 x bottle gearbox oil (80W/90)
- 2 x manual release keys

MOTOR UNIT COIMPLETE

(see below for identification of operator components)

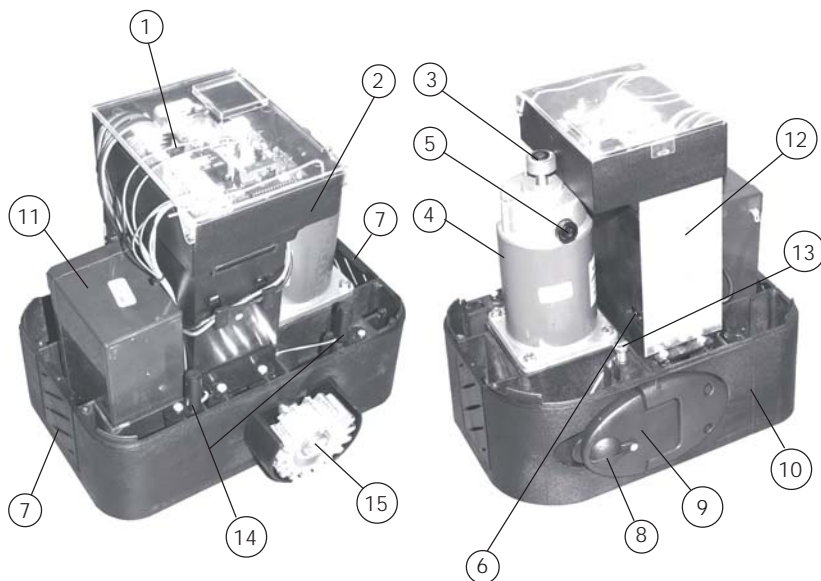

Figure 3.1

1. CONTROL CARD
2. CONTROL BOX WITH LID
3. EIGHT POLE RING MAGNET
4. MOTOR
5. REPLACEABLE MOTOR BRUSHES
6. POWER SUPPLY UNIT AC PRESENT LED (ACDC ONLY)
7. REMOVABLE SIDE VENT TO GAIN ACCESS TO MOUNTING HOLES
8. LOCK FOR MANUAL RELEASE
9. MANUAL RELEASE ASSEMBLY
10. GEARBOX
11. 12V BATTERY
12. PSU POWER SUPPLY UNIT FOR ET-500 ACDC (ET-500 12V COMES WITH PLUG-IN TRANSFORMER).
13. OIL FILLER PORT
14. MAGNETIC REED LIMIT SWITCHES
15. PINION GEAR

TECHNICAL SPECIFICATIONS

TECHNICAL DATA	ET-500 12V	ET-500 ACDC
POWER SUPPLY ¹ AT GATE	16V AC 1AMP via 220-16V AC transformer	220V, +/-10%, 50Hz
MAXIMUM ABSORBED CURRENT @ 220V AC SUPPLY	190mA	3A
MOTOR VOLTAGE	12V DC	12V DC
MAXIMUM STARTING THRUST	< 30kgF set	< 30kgF set
MAXIMUM RATED RUNNING THRUST	22kgF set	22kgF set
GATE SPEED ²	17m/min	17m/min
DUTY CYCLE AT RATED RUNNING THRUST	20% ³ @ running thrust less than 10kgF	100% on PSU ⁴ 20% battery ³ backup @ running thrust less than 10kgF
OPERATING TEMPERATURE RANGE	-10 / +50 °C	-10 / +50 °C
ANTI-CRUSHING SENSING	ELECTRONIC	ELECTRONIC
UNIT MASS	11.4kg (incl. battery & plug-in transformer)	13.3kg (incl. battery & PSU)
MAXIMUM GATE LENGTH	9m	9m
MAXIMUM GATE WEIGHT	500kg	500kg
AUXILIARY OUTPUT FOR ANCILLIARIES	12V DC at 200mA	12V DC at 200mA
BATTERY CHARGE VOLTAGE	13.6V DC	13.6V DC

1 - Alternate source of supply is a solar charger or on 12V model an inline on plate transformer at gate

2 - When measured with mains of 230V AC and battery fully charged and gate running load of 5kgF maximum. Lower load = higher speed. Higher load = lower speed.

3 - 12V 7AH battery fully charged

4 - PSU power supply unit ET-500 ACDC model only

OPTIONAL EXTRAS

- 1, 2, 3, 4, or 6 button transmitters
- Safety infra-red beams or other safety device
- Free-exit loop detector
- Multi-user receiver
- Keypad or other trigger device for pedestrian open
- Fasteners and fixings for attaching rack to gate leaf.
Please investigate the best type for your gate leaf material.
- Anti-theft bracket & lock
- Padlock for anti-lift bracket

PLEASE CONTACT YOUR E.T. PRODUCT SUPPLIER FOR MORE
INFORMATION OR TO ORDER THE ABOVE.

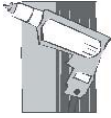

electric drill and assorted drill bits



13mm spanners/ wrenches



2.5mm blade flat screwdriver



PH02 Phillips screwdriver



hacksaw



tape measure



spirit level



shovel



sidecutters



angle-grinder

BEFORE ATTEMPTING TO INSTALL A SLIDE GATE OPERATOR, PLEASE BE CERTAIN YOU HAVE READ AND UNDERSTOOD THE FOLLOWING:

The following are points to note before installing your new slide gate operator operator:

1. Gate mechanics
2. Cabling requirements
3. Model type application

1. GATE MECHANICS

a) Gate Leaf

Gate leaf must be sound and of sufficient construction to withstand an operator of this type (see technical specifications).

Gate leaf should be straight and true with minimal deviation to the facia that the rack must attach to (no 'banana-effect').

b) Wheels

Recommended wheel type and size for this automation is steel or steel alloy, machined or cast wheels of at least 100mm diameter using sealed roller bearings (see next page).

For wheel profile, see the three types below:

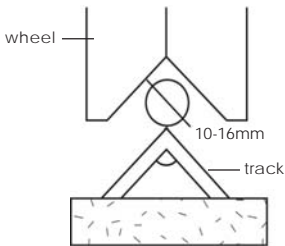

RECOMMENDED
Figure 7.1

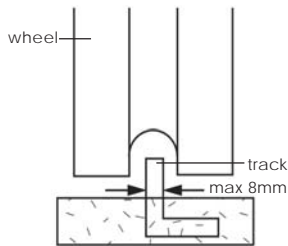

SECOND OPTION
Figure 7.2

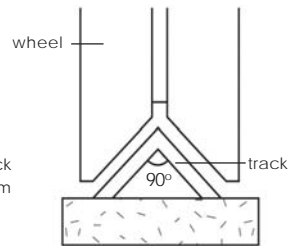

PROBLEMATIC
Figure 7.3

c) Guides

The recommended vertical guide type is nylon wheel encasing a sealed bearing (see sample below).

RECOMMENDED TYPES OF GUIDE AND WHEELS



Figure 8.1

e) Track

Note the recommended track type in figures on page 7. The track must be secure, straight, level and free of all obstructions. Install physical stopper at the ends of the gate travel to avoid the gate over-running the ends of the track as shown in figure 8.2.

d) Gate Travel

Using a fish-scale, as shown below, pull the gate fully open and fully closed. For optimum duty cycle, ensure that the maximum resistance at any point does not exceed 10kgF.

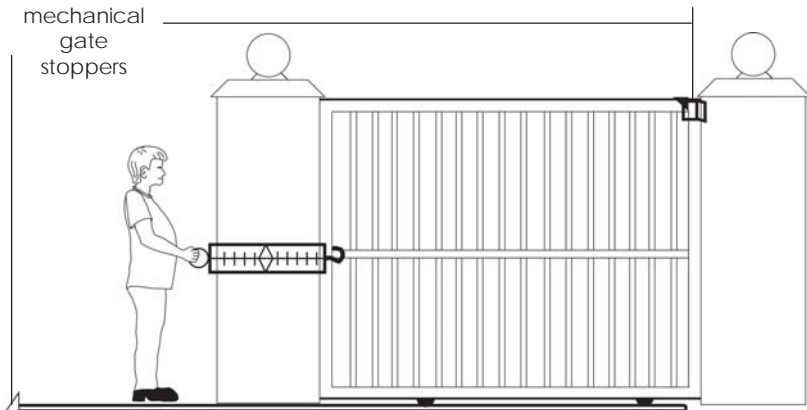

Figure 8.2

2. CABLING REQUIREMENTS

Before mounting the operator ensure your cabling and conduiting are in place to prevent any inconvenience at a later stage. Allow for spares in case of faulty cable & breakages (especially important when using low specification cable). If installing an intercom, remember to allow for sufficient cable cores for all the uses on the system as per manufacturers cabling requirements.

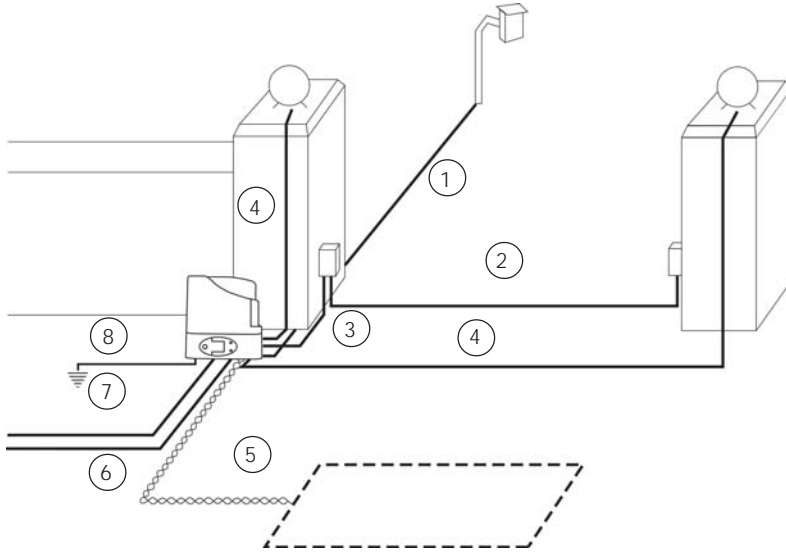

Figure 9.1

1. Intercom gate station (check with intercom supplier specifications)
2. Safety infra-red beam power (2-core)
3. Safety infra-red beam power & switch (4-core)
4. Courtesy lights (twin + earth 1.0mm)
5. Free exit loop (1.5 silicone insulated)
6. Primary power:
 - a) ET-500 12V (16V AC) - twin: min 0,5
 - b) ET-500 ACDC (220V AC) - twin + earth: 1,0
 - c) ET-500 12V internal in-line transformer (220V AC) - twin + earth: 1,0
7. From intercom internal equipment (check with intercom supplier specifications)
8. Optional earth-rod for high lightning strike areas (preferably use household earth leakage)

3. MODEL TYPE APPLICATION

ET-500 ACDC = high traffic commercial model

ET-500 12V = low traffic domestic model

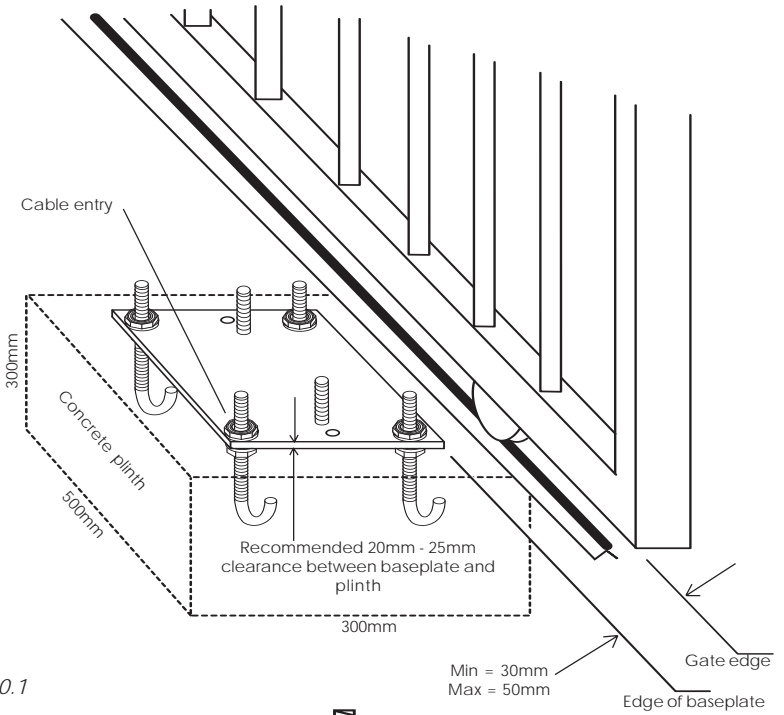

Figure 10.1

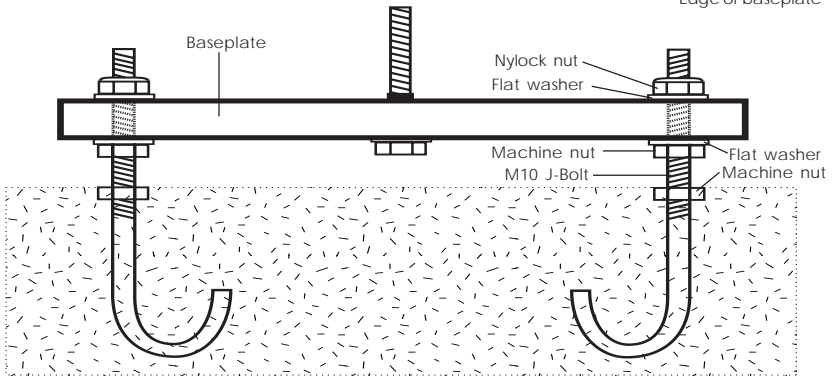
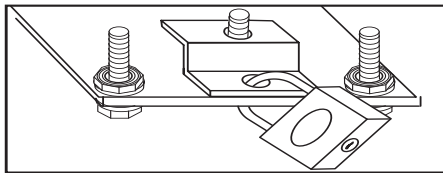

Figure 10.2



Once motor has been installed, the anti-lift bracket can be used as shown here.

Figure 10.3

HOT TIP: Cast motor and track plinth as one piece wherever possible

Gearbox Mounting

Before mounting the gearbox on a base plate that has been newly cast, ensure that you have allowed sufficient time for the concrete to set and cure as movement will detrimentally affect the sturdiness of your motor fixings.

Please note:

When positioning the gearbox, you should allow a minimum of 5mm between the fascia of the pinion and the fascia of the gate leaf so as to avoid the gate leaf scraping against the pinion.

Use the 2 x M8 nylock nuts with 2 x 8mm flat washers to fasten your gearbox to the base plate.

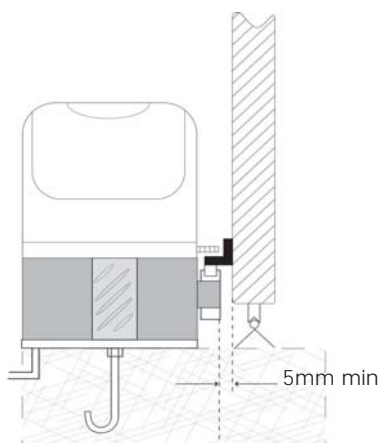

Figure 11.1

DISPENSE OIL

A dry gearbox is manifested by excessive gearbox noise and can cause difficulty in manual releasing of unit (80W/90 transmission oil).



Figure 11.2

Once the gearbox has been mounted, proceed to Step 2 - Mounting Of Rack

STEP 2 - MOUNTING OF RACK

Below, is your final positioning required with regards to the spacing between your rack and pinion gear.

Ensure that the rack does not rest heavily on the pinion at any point.

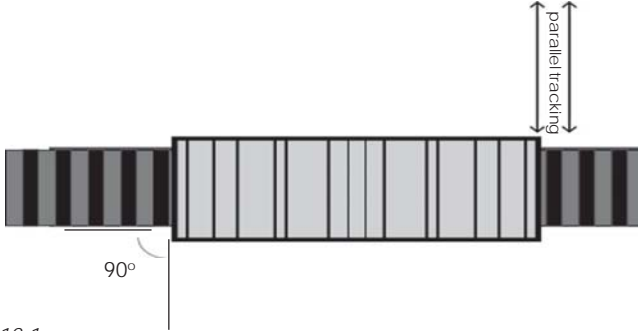
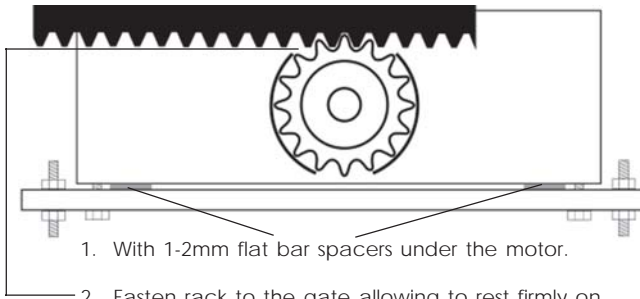
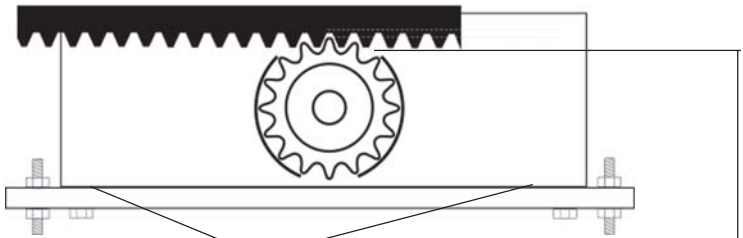

Figure 12.1



1. With 1-2mm flat bar spacers under the motor.

2. Fasten rack to the gate allowing to rest firmly on the pinion gear throughout its travel



3. Remove the spacers to give you an equal 1-2mm tolerance between the rack and pinion throughout the gate travel.

Figure 12.2

Factory default gate direction as viewed here - closing left

1. Close gate hard up to the closed stopper.
2. Fasten the limit actuator onto the rack by removing a rack mounting screw and replacing it with the long self taper supplied.

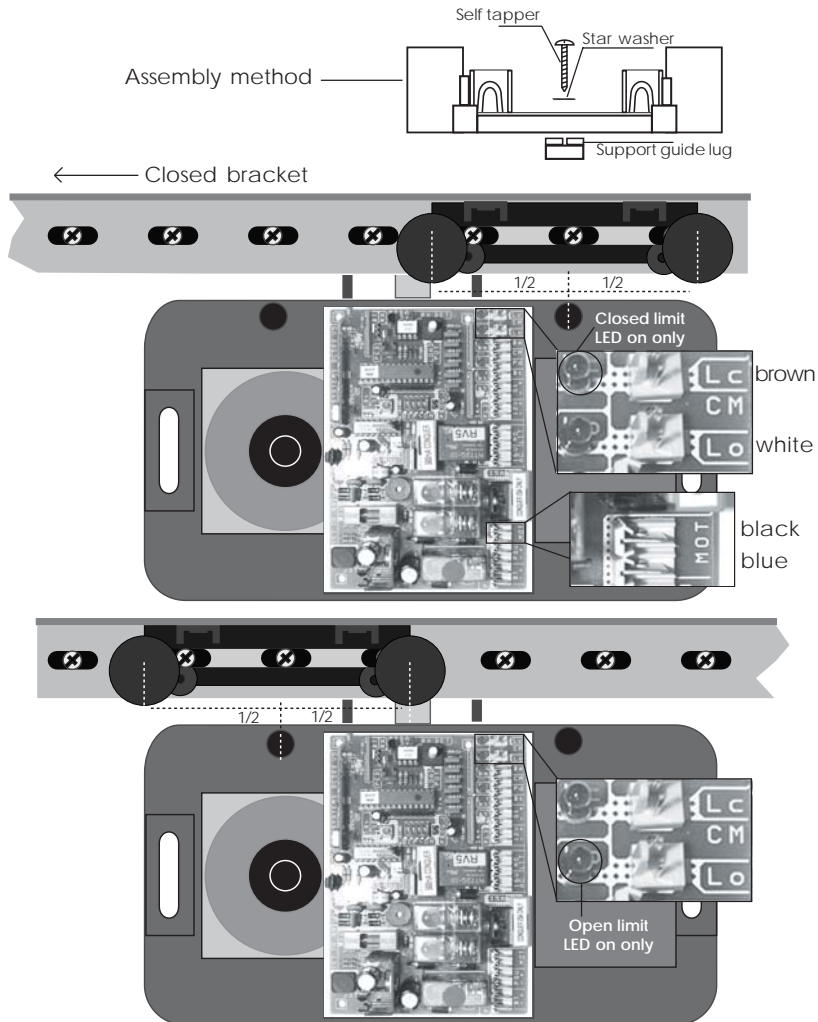

Figure 14.1

If your motor closes to the right when viewed from this angle, swop both your motor wires and limit switch wires around

STEP 4 - ADJUSTING MOTOR FINAL POSITION

Refer back to figure 8.2 on page 8.

Now that you have completed the mechanical installation, before proceeding with programming and set up, double check the gate load with the operator manually released.

Pull the gate through its full travel, open and closed, to check that the gate is not snagging or the rack is not riding up of the rack on the pinion.

Your gate should not exceed 10kgF with the motor in final position to obtain the optimum duty cycle.

Your hardware is now installed. Proceed to wiring and programming.

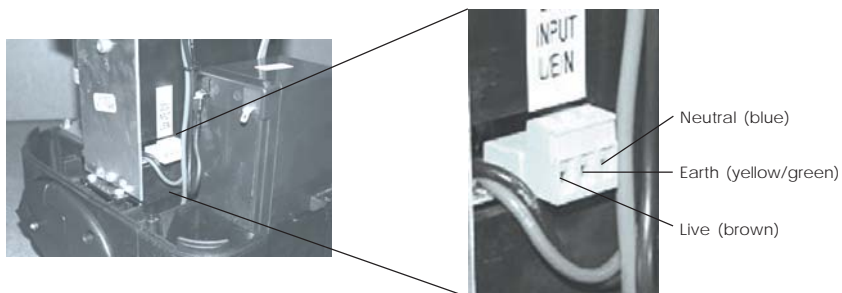

Figure 15.1

3. POWER SUPPLY (ET-500 ACDC MODEL ONLY)

- 3.1 As this is a high-voltage power supply unit, double check that the mains is isolated before beginning the above.
- 3.2 Ensure that the power supply unit located behind the aluminum heatsink is kept clear of insects and other forms of infestation.
- 3.3 You can access the power supply by removing the three screws indicated in figure 15.2 below and then gently, yet firmly, pull the entire power pack unit out of its housing.
- 3.4 Check 2A Conquer brand only fuse located behind aluminum plate in case of AC LED not being on.

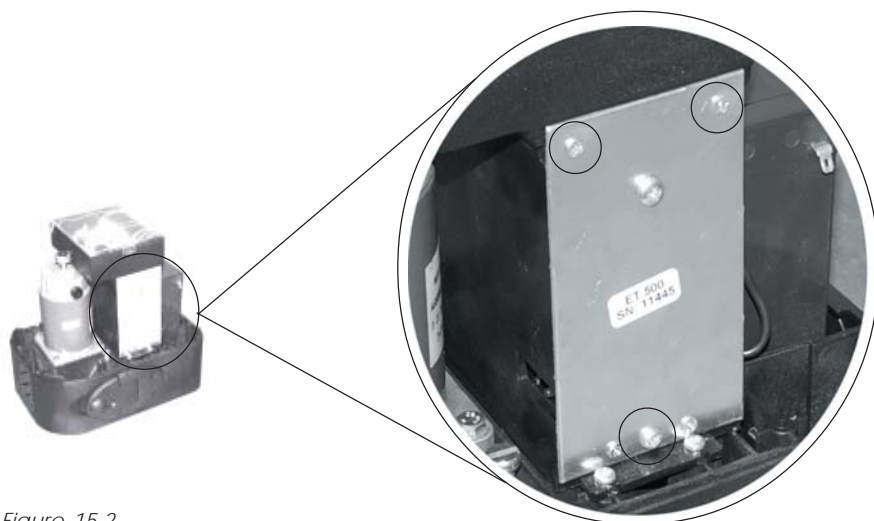

Figure 15.2

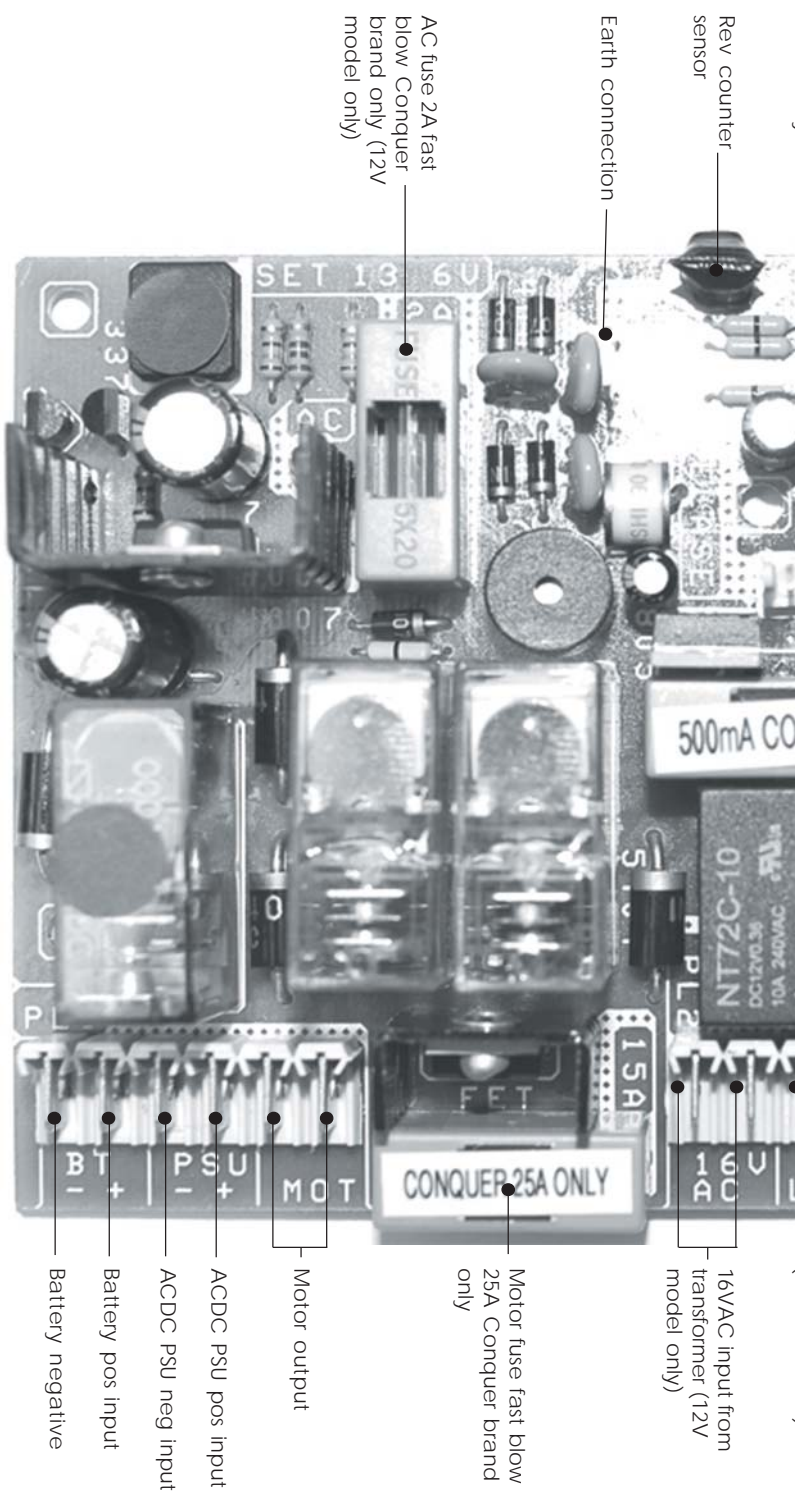
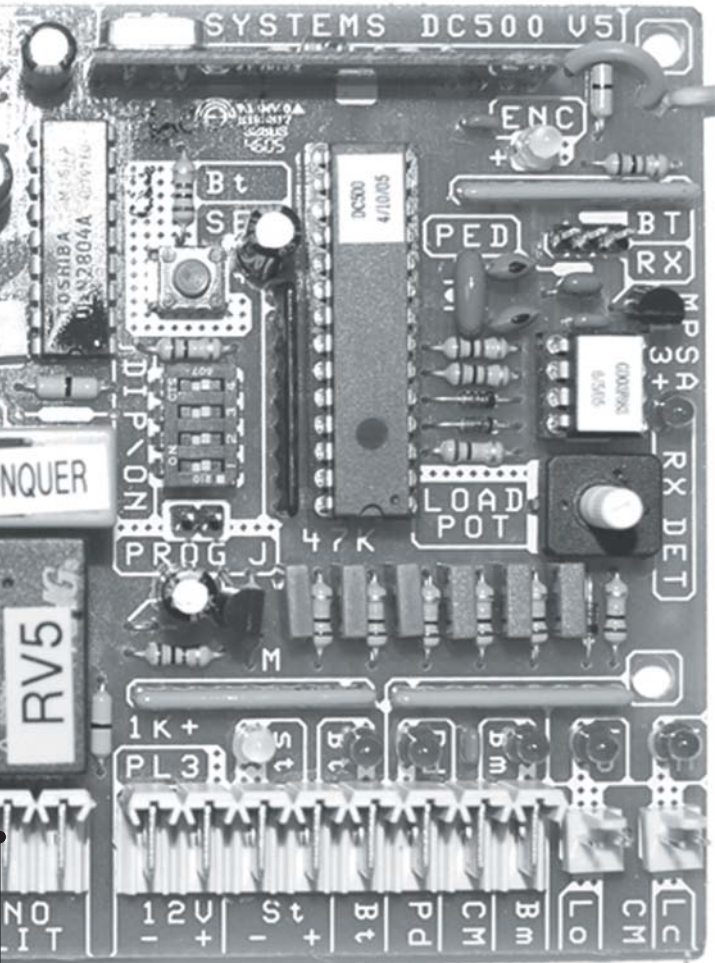

Figure 16.1



- Rev counter confirm LED
- Rx prog pins
- Rx confirm LED
- Load sensitivity adjustment
- Status LED
- BT input LED (normally OFF)
- Pd input LED (normally OFF)
- Beam input LED (normally OFF)
- Open limit LED (ON when gate is open)
- Closed limit LED (ON when gate is closed)

- Closed limit input
- Open limit input
- From beam N/O
- Common output to com of beam, Rx, ...
- From pedestrian N/O
- From full travel button trigger
- Status LED + output
- Status LED -output
- Aux 12VDC + output max 500mA
- Aux 12VDC - output max 500mA

- Aux 12VDC output fuse - 500mA Fast blow Conquer brand only

N/O volt free courtesy light switch (3 min timeout) 3A max

- Programming/ mode selection switches
- Programming/test button
- Prog Jumper

Onboard receiver programming:

Hot tip: - It is advisable to master erase on first time setup.

Master erase procedure:

1. Power down
2. Short all three receiver-programming pins (Bt – Middle – Ped) together. Hot tip: - *You can use a key ring supplied with transmitter to do this.*
3. Power up with short in place.
4. When RX LED has comes back on permanently after flashing, remove short and power down again.
5. Re-apply power without any shorts in place.

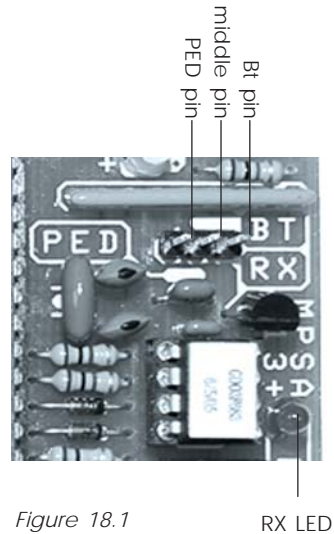

Figure 18.1

RX LED

To program a user's transmitter into the Bt full opening/closing option:

Hot tip: - hold transmitter +/- arms length away from motor unit when programming the receiver

1. Press and hold required button on users transmitter.
2. While holding transmitter button momentarily short Bt pin to the middle pin.

RX LED will flash confirmation of user button learnt.

Repeat for additional Bt users

- a. 1 x flash = first user programmed into memory for this function
- b. 2 x flashes = more memory still available
- c. 10 x flashes = maximum memory reached (25 Bt users)
- d. No flashes = Unsuccessful due to incorrect transmitter type, required button already programmed into Ped option or faulty transmitter/transmitter battery

To program a users transmitter into the Ped pedestrian opening option:

1. Press and hold required button on users transmitter.
2. While holding transmitter button momentarily short Ped pin to the middle pin.

RX LED will flash confirmation of user button learnt.

Repeat for additional pedestrian users

- a. 1 x flash = first user programmed into memory for this function
- b. 2 x flashes = more memory still available
- c. 10 x flashes = maximum memory reached (5 Ped users)
- d. No flashes = Unsuccessful due to incorrect transmitter type, required button already programmed into Bt option or faulty transmitter/transmitter battery

If a transmitter button has been learnt into the incorrect function, it must be deleted from that function first to be able to learn it into the correct option.

To erase an individual transmitter button without interfering with memory allocated to other users on the receiver:

NOTE: The following is carried out with power present at all times.

1. Short all three receiver-programming pins (Bt – Middle – Ped) together. *Hot tip: - You can use a key ring supplied with transmitter to do this.*
2. Press and hold the transmitter button you need to erase from the receiver memory.
3. When RX LED begins to flash release transmitter button and remove short.

Repeat to erase additional transmitter buttons.

The button used for Bt cannot be used for PED and visa versa (The LED will not flash confirmation if you try this)

Only one button per transmitter can be learnt into an input.

PROGRAMMING

1. To enter program mode, switch all dipswitches off.
2. Place jumper supplied across 2 pins PROG J

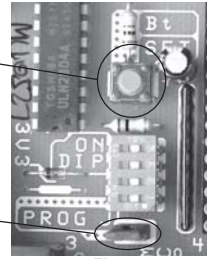

Figure 20.1

1 – Run Time Setup

- 1.1 With all dipswitches off press & release SET button
- 1.2 Gate will close to close limit
- 1.3 Gate will stop and re-open to open limit
- 1.4 Gate will stop and close again.
- 1.5 Control card will beep once to confirm end of run time setup.

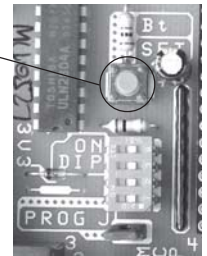

Figure 20.2

Remove PROG jumper to exit program mode or select another programming feature.

2 – Auto close Time (This does not activate autoclose. See ‘Selecting Mode Options’ on page 22)

- 2.1 Switch dipswitch 1 ON
- 2.2 Press & hold SET button
- 2.3 PCB will beep (1beep = 1 sec)
- 2.4 Release SET button at required auto-close time
- 2.5 Switch dipswitch 1 OFF

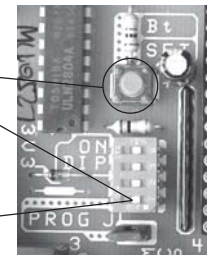

Figure 20.3

(PCB will emit a continuous beep until dipswitch is switched off)

Remove PROG J jumper to exit program mode or select another programming feature.

3 - Pedestrian Opening

- 3.1 Switch dipswitch 2 ON
- 3.2 Press and release SET Button
- 3.3 Gate closes to close limit and re-opens
- 3.4 Press and release SET button to stop gate at required pedestrian opening distance

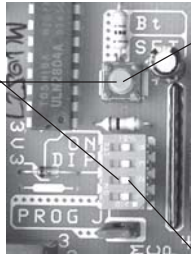

Figure 21.1

- 3.5 Press and hold SET button. Control card will beep (1 beep = 1 sec)
- 3.6 Release SET button at required pedestrian auto-close time. Gate then closes.
- 3.7 Gate stops at closed position and the PCB will emit a continuous beep.
- 3.8 Switch dipswitch 2 OFF

Remove PROG J jumper to exit program mode or select another programming feature.

4 - 350mm Crawl Programming (Optional if needed)

- 1.1 With dipswitch 4 ON, press & release SET button
- 1.2 Gate will close to close limit
- 1.3 Gate will stop and re-open to open limit
- 1.4 Gate will stop and close again.
- 1.5 At close position, PCB will emit a continuous beep.
- 1.6 Switch dipswitch 4 OFF.

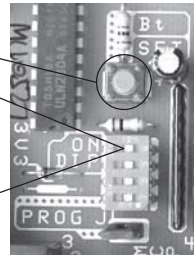

Figure 21.2

5 - Load Setting Adjustment

To adjust the load setting on the unit, make use of the load adjustment POT on the control card as indicated in Figure 22.1 on page 22.

After every adjustment on the POT, the control card will indicate the load setting by beeping when triggered to run. The load increases or decreases from 1 beep minimum to 5 beeps maximum.

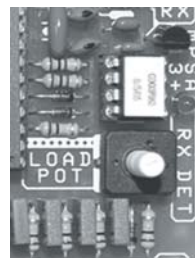

Figure 21.3



SETTING UP OF MODES (PROG J jumper OFF)

- Standard Mode (all OFF)
- Auto-close Mode (1 ON only)
- Condominium / Free exit Loop Mode (2 ON only)
- P.I.R.A.C. Mode (3 ON only)

- Standard Mode (All dipswitches OFF)

When the unit is activated it will open and can be stopped in mid-cycle by pressing the transmitter or manual push button, and likewise when closing.

The unit can then be reversed by pressing the transmitter or push button. In standard mode the gate will remain on its open limit until it is triggered to close (no auto-close).

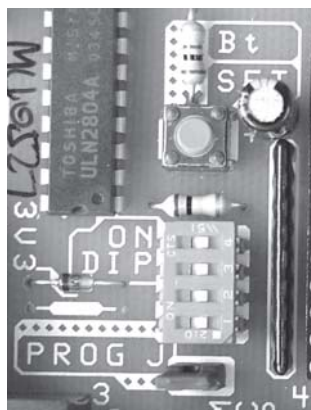

Figure 22.1

- Auto-close Mode (dipswitch 1 ON)

When auto-close is activated and the gate opens to the open limit, the unit will wait the pre-programmed time (see '2-Auto-close' on page 24) before automatically closing. If the unit is triggered while the gate is in its closing cycle it will stop and re-open.

To override the auto-close, wait until the gate reaches its open limit then press and hold the transmitter or manual push button for 5 sec (the control card will beep to confirm the override).

To reactivate the auto-close, press the transmitter or manual push button.

If the transmitter or manual push button is pressed while the gate is opening, the gate will stop and then auto-close after programmed time.

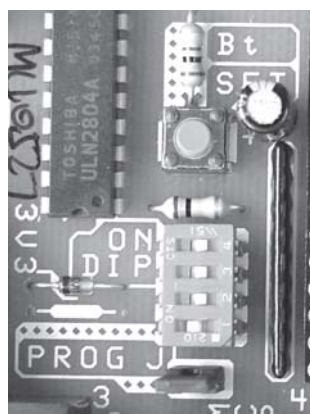

Figure 22.2

- Condominium/free exit loop Mode (dipswitch 2 ON)

When condominium/free-exit loop is activated on the unit, the unit will not respond to any transmitter or manual push button while it is opening or open.

When the gate is on the open limit the unit will automatically wait the pre-programmed auto close time and then close (even if auto-close is not selected - dip 1).

When the gate is closing or closed and the transmitter or manual push button is pressed the gate will stop and open.

In condominium mode, the controller will only allow for 10 full operations in case of power failures. On the 10th opening, the gate will remain open until power is restored. This is to minimise deep discharge damage to the battery.

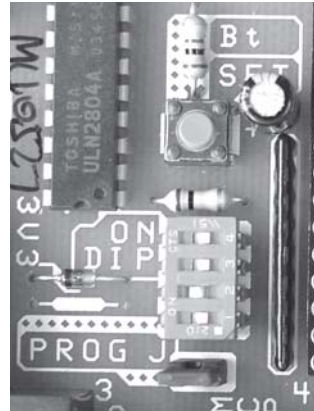

Figure 23.1

- P.I.R.A.C. Mode: Passive Infra-Red Access Control (dipswitch 3 ON)

With P.I.R.A.C. mode selected if something passes through the beams while the gate is opening, the gate will stop and close immediately. If the beams continue to be blocked while the gate is opening, the gate will continue to open to the open limit where the controller will wait for the beams to be cleared.

If the gate opens fully to the open limit, it will close after programmed auto-time)

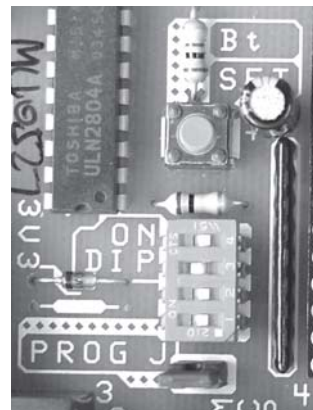

Figure 23.2

If any problems occur, remove all external wiring at PCB and test as per your mode selection as detailed on pages 22-3 in this manual.

Audible Troubleshooting Guide

	Tone and Action	Condition	Action To Remedy
A	1 x long beep on closing of manual release door	Control card has reset and is ready for next command	The next trigger will cause the gate to crawl until closed limit is found. Continue normal use after gate is fully closed.
B	1, 2, 3, 4 or 5 short beeps on first trigger after reset tone	Control card is confirming load sensitivity to physical obstructions 1 = most sensitive; 5 = least sensitive	If satisfied with safety sensitivity, continue normal use. If not, contact your service provider.
C	2 x long beeps after a trigger and before gate starts moving	Mains power interruption	Restore mains power.
D	3 x rapid beeps and gate won't open	Holiday lock-out is active	De-activate holiday lock-out by pressing and holding pedestrian trigger until the control card begins 5 long tones. At start of the first tone, release the trigger.
E	1 x continuous tone as long as gate trigger is depressed and gate won't move	Maximum closing collisions exceeded. If no obvious obstruction is apparent, then open and close the gate manually feeling for higher points of resistance. Your gate mechanics may need re-alignment or a service, even if the gate is only a few months old. New gates settle on freshly laid concrete as it dries out. Alternatively your load sensitivity may be incorrect for your gate size (see B above)	Manually release the gearbox and slide gate away from obstruction. Clear obstruction. Re-engage the gearbox and continue use. If problem repeats, contact your service provider. <i>On models that do not reset on use of the manual see A above. Allow 3 minutes after clearing obstruction for status to clear.</i>
A&C	2 x long beeps followed by 1 x long beep when gate triggered	Mains power interruption and battery reserve depleted (12V and ACDC models)	Restore mains power and allow +/- 8 hours for battery to recharge. If after 8 hours (F) below occurs, contact your service provider.
F	Gate stops moving, followed by 1 x long beep	Battery depleted	Allow 8 hours recharge time with household mains present. If problem remains after 8 hours, contact your service provider to purchase a new battery.
G	3 x long beeps and gate opens	Pedestrian opening trigger has been used	See using the pedestrian option on page 3.