

QUICK SETUP GUIDE

© Centurion Systems (Pty) Ltd. 1150.D.01.0012_7

UPDATED FOR V2 OPERATORS

This guide is intended for the experienced installer who has done an R3 or R5 installation before, knows all the safety aspects required of a site, but who needs reminding of the basic steps to follow.

This guide does not replace the manual, but is supplementary to it.

WARNING

Always ensure that all safety instructions as described in the Installation Manual are adhered to during the installation process, and also apply to the completed installation.

TIP!! If in doubt refer to the installation manual. (IM)

1 REQUIRED TOOLS & EQUIPMENT

Check that you have all the tools required. (IM page 12)

2 SITE CONSIDERATIONS

- Check for the safety and suitability of the site by looking at: (IM page 13)
- All safety and local authority requirements.
- That the gate is within the operator specifications.
- Check that there is enough ground clearance to enable assembly of the drivearm clamps. (See Figure 4)

3 CABLING REQUIREMENTS

Consider all cabling requirements and routing as in Figure 9. (IM page 14)

4 OPERATOR INSTALLATION

- Estimate the gate swing angle with figure 1.
- Then mark the operator's position according to figure 2 or 3. (IM page 15)

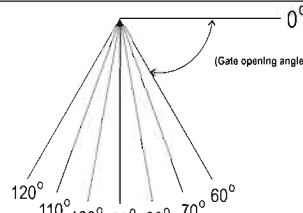

Figure 1 Gate Opening Angle Diagram

STANDARD PEDESTAL MOUNT

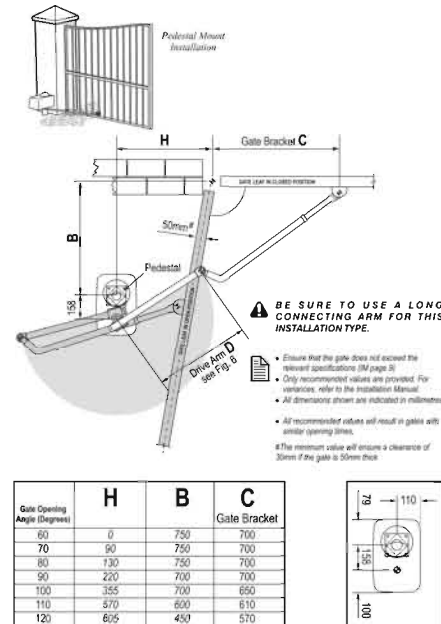

Figure 2 Standard Pedestal Mount Installation

PERPENDICULAR WALL MOUNT

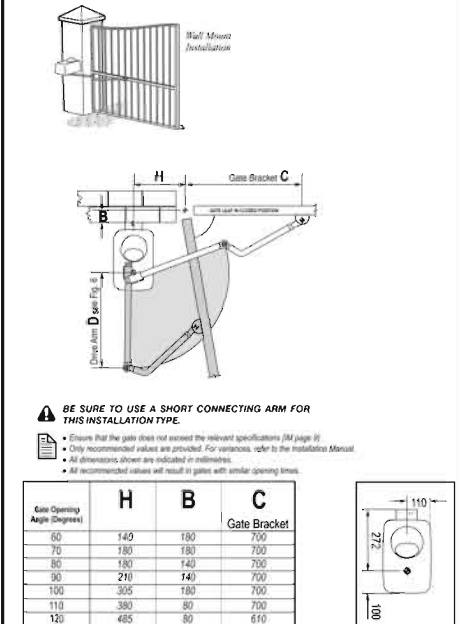

Figure 3 Standard Wall Mount Installation

9 FIT THE DRIVE ARM

- Put the gearbox into manual mode. (IM page 24).
- Fit the drive arm to the operator as shown.

ASSEMBLE CLAMP TO DRIVE ARM

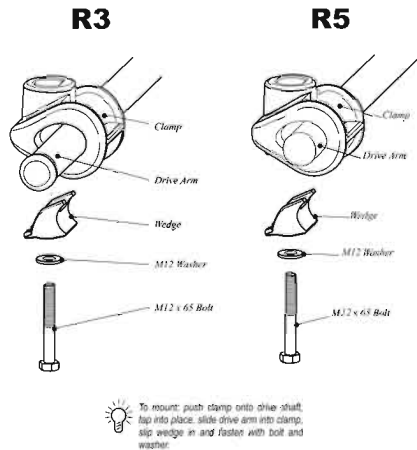

Figure 7 Assemble Clamp to Drive Arm

7 FASTEN GEARBOX IN POSITION

- Fasten the motor onto the pedestal adaptor plate or the wall bracket using the M8 bolts and washers supplied. (IM page 23)

8 CUT DRIVE ARM TO LENGTH

- Using the relevant tables below, read off the required drive arm length.
- Then cut the drivearm 50mm longer than D, as shown in Figure 6.

CUT DRIVEARM TO LENGTH

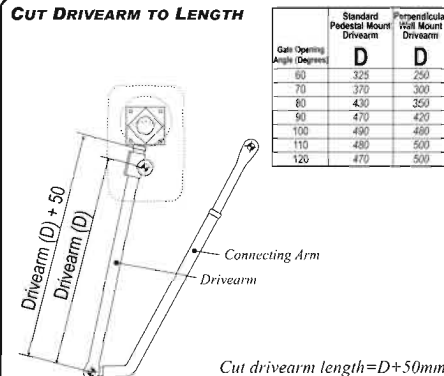

Figure 6 Cut Drive Arm Length

WALL MOUNT INSTALLATION

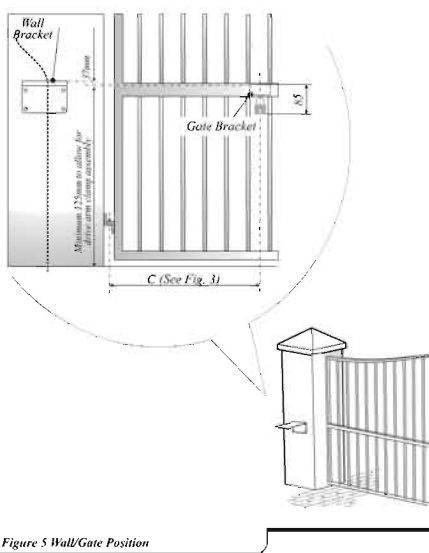

Figure 5 Wall/Gate Position

6 ROUTE CABLES & SECURE MOTOR

- Route cables as determined in the cabling plan in Figure 9.
- Make sure at least 400mm of cable protrudes above the pedestal or wall mount bracket. (IM page 22)

5 MOUNT THE GATE BRACKET AND DETERMINE PEDESTAL HEIGHT

- Locate a suitable place for mounting the gate bracket according to dimension "C" in the tables of Figures 2 or 3.
- Determine pedestal or wall mount bracket height relative to gate bracket as in figure 4 and 5. (IM page 21)
- Mount the gate bracket.

PEDESTAL MOUNT INSTALLATION

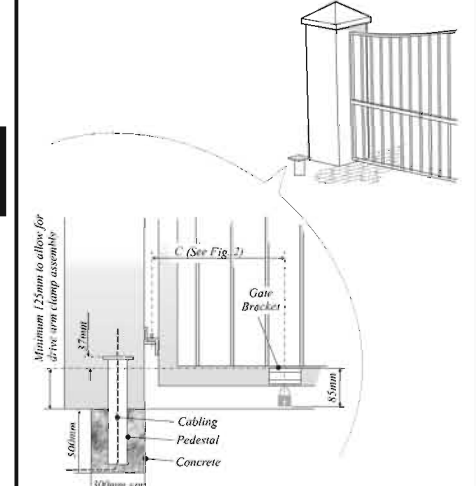

Figure 4 Pedestal/Gate Bracket vertical position



10 SET THE CONNECTING ARM LENGTH

- Loosen the connecting arm slightly and move it to its fully retracted position.
- Open the gate 1/2 way.
- Assemble the connecting arm to the gate bracket.
- Now slowly push the gate to its closed position. (The drive arm will turn, and the connecting arm will extend while doing so)
- Check that the hinge points of the gate bracket, connecting arm and motor output shaft are in a straight line as shown in Figure 8.
- Carefully unhook the connecting arm from the gate bracket and tighten lightly.
- Check the gate opens and closes sufficiently by manually operating the gate.

IF THE GATE OPENS TOO LITTLE
Lengthen the drivearm by 10 mm and readjust the connecting arm.

IF THE GATE OPENS TOO MUCH
Shorten the drivearm by 10 mm and readjust the connecting arm.

- Fully tighten connecting arm.
- Apply the warning decals supplied to either side of the gate frame.

ALIGNMENT OF HINGE POINTS

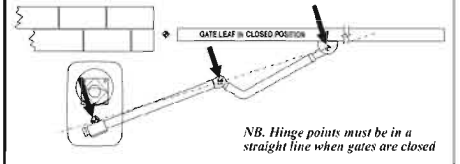

Figure 8 Align Gates

ELECTRICAL SET-UP

- ⚠ WARNING**
- Always check that the circuit breaker in the electrical panel is in the OFF position, and that all high voltage circuits (more than 42.4V) are completely isolated from the mains supply before doing any work.
 - Ensure that all low voltage systems (less than 42.4V) are suitably protected from damage, by disconnecting all sources of power such as chargers and batteries before doing any work.
 - All electrical work must be carried out according to the requirements of all applicable local electrical codes. It is recommended that a licensed electrical contractor perform such work.

1 CONNECT ALL WIRING

- Connect all cables as required to the control card and battery charger (See Figure 11 & 12). (IM page 48 & 49)
- Check that the power source jumper is in the correct position. (PSU or STD refer to IM page 27, Fig. 24)

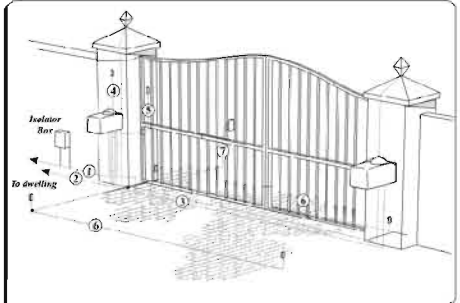

Figure 9 Cabling Requirements

CABLE REQUIREMENTS

- 220V AC mains cable (3 core LNE 0.5mm²*) via mains isolator switch
Or
Low voltage 16V AC battery charger supply (2 core 1.5mm²)†
 - Intercom cable (n1 – 6 core) to house.
 - Slave motor cable (if required) (3 core 2.5mm² – 3 core 0.5mm² multistranded).
 - Radio receiver cable (3 core 0.5mm² multistranded).
 - Pedestrian key switch (if required) (2 core 0.5mm² multistranded).
 - Infrared beams or safety edge (if required) (3 core 0.5mm² multistranded).
 - Intercom cable (n2+2 core 0.5mm² multistranded) to gate station.
- n1 = number of cores required by intercom. n2 = number of zones required by Intercom.
* Increase cable thickness if plastic lights are to be installed.
† Sealed cable is always recommended to provide better protection against lightning – earth one end of screening.

2 SET UP THE GATE ORIGIN

- Release the manual override and close the gate(s).
- Use the origin tool and line up marks as in figure 10. (IM page 28)
- Open gate 1/2 way and unscrew the manual release mechanism. (IM page 28).

SETTING THE GATE ORIGIN

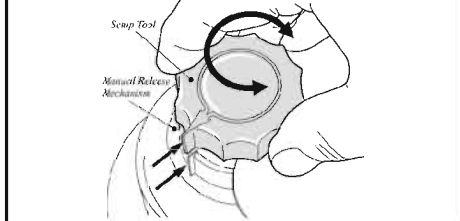

Figure 10 Origin Setup

3 GET INTO PROGRAMMING MODE

- Remove all power. (IM page 28)
- Fit the SET link.
- Reapply power

4 SELECT EITHER MASTER OR SLAVE SETUP

- Press and hold the TEST button, release after 1 flash of L1.
- Then again, press and hold the TEST button, and release after 1 or 2 flashes of the STATUS LED. (1 Flash=master, 2 Flashes=slave) (Installation Manual page 29)

5 SET THE GATE LIMITS

- Press and hold TEST until the gate is closed, and then release.
- NB: THE GATE MUST CLOSE. IF IT OPENS:
 - Release the TEST button.
 - Swap the respective motor wires.
 - Press and hold TEST until gate is closed, and then release.
- Press and hold TEST until gate is open, and then release.
- Press and release TEST (When setting up the MASTER gate, it will close and then open to pedestrian. IM page 29).
- If setting up the master gate, press and release TEST once more to complete the setup (The MASTER gate will open fully, and the SLAVE gate will move slightly).

6 SETTING ADDITIONAL FEATURES (OPTIONAL)

- Determine what features are required (See Table 2). (IM page 47)
- Get into programme mode (as in Step 3), or continue from Step 5.
- To select the Feature to Change: (IM page 31)
 - Press and hold the TEST button while monitoring L1:
 - Example of how to select the AUTOCLOSE feature: The L1 light will flash once and pause... Then flash twice and pause...

TRIGGER CONNECTIONS

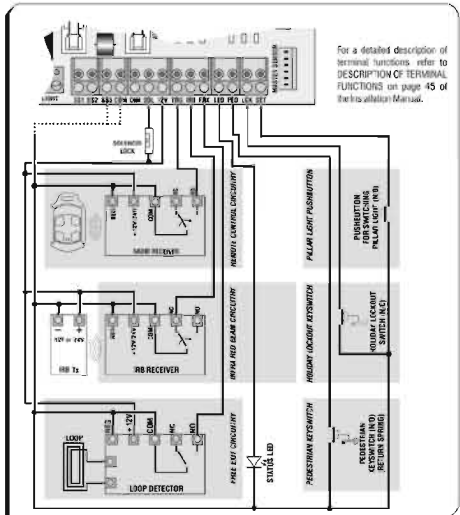

Figure 12 CP75 Controller Trigger Connections

8 PERFORM INSTALLATION HANDOVER

- Explain to the user how to SAFELY operate the gate. (IM, page 51.)

CP75 BASIC CONTROLLER CONNECTIONS

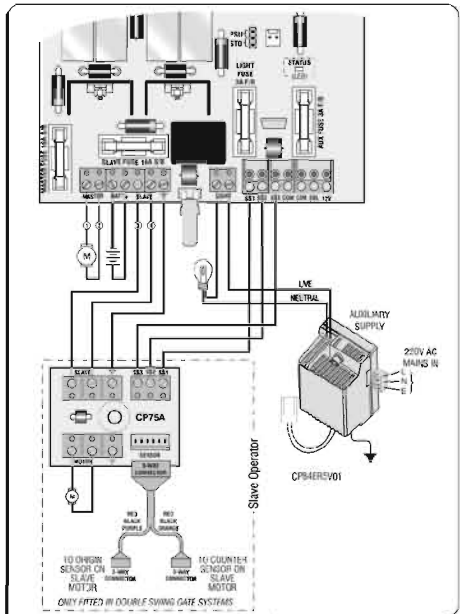

Figure 11 CP75 Controller Connections

CP75 CONTROLLER FUNCTIONS

FEATURE DESCRIPTION	FEATURE NUMBER	STATUS or COUNT		DESCRIPTION
		STATUS VALUE	COUNT VALUE	
Gate Limit Settings	1	-	-	See detailed instructions on page 29
Auto-close	2	1	-	ON
Auto-close Time	3	2	-	OFF (Default)
Mode of Operation	4	1	-	15 seconds (Default)
		2	-	STANDARD (Default)
Pedestrian Auto-close	5	3	-	CONDOMINIUM
		4	-	PIRAC
Courtesy Light	6	-	1 Flash = 1 second	5 seconds (Default)
Collision Sensitivity	7	1	-	120 seconds (Default)
		2	-	HIGH (Default)
Auto-close Override	8	3	-	MEDIUM
		4	-	LOW
Positive Close Mode	9	1	-	3 seconds (Default)
Prelatching	10	2	-	ON
		1	-	OFF (Default)
		2	-	MODE 1
		3	-	MODE 2
Prelatch Time	11	4	-	MODE 3
		1	-	OFF (Default)
Collision Counter	12	2	-	2 seconds (Default)
		1	-	1 Flash = 1 second
Leaf Delay Select	13	1	-	Delay on slave opening
		2	-	Delay on master closing
		3	-	Delay on slave opening & master closing
		4	-	Delay off (Default)
Leaf delay time / Sustained Stroke Time	14	-	1 Flash = 1 second	2 seconds (Default)

Table 2 Controller Functions Menus and Submenus

7 EXIT PROGRAMMING MODE

- At this moment release the TEST button to select feature number 2. (L2 will turn off, and L1 will keep on flashing 2 times and pausing to indicate that feature number 2 is selected).
- NOTE: The STATUS of the Feature is not changed yet, the feature has only been selected to be changed!**
If an incorrect Feature is selected, then remove and re-apply power and repeat the procedure.
- To change the STATUS value of a Feature: (IM page 31)
 - Press and hold the TEST button while monitoring the STATUS light:
 - (Continues from above example to set autoclose to ON status). The L1 light will flash once and pause.
 - At this moment release the TEST button to give a STATUS value of 1. The AUTOCLOSE feature has been set to ON
 - NOTE: Only after setting the STATUS, would the AUTOCLOSE be turned ON.**
(L2 will come back on, indicating that the STATUS has been set.)
- To change the COUNT value of a Feature: (IM page 31)
 - Press and hold the TEST button while monitoring the STATUS light:
 - After a slight pause, the STATUS light will start flashing regularly: Flash (1), Flash (2), Flash (3), Flash (4), Flash (5), Flash (5) Flash (9), Flash (10).
 - At this moment release the TEST button to give a COUNT value of 10. This could for example be the prelatching time. (L2 will come back on, indicating the COUNT value has been set).
- Remove the SET link.

