



CENTURION SYSTEMS (PTY) LTD HEAD OFFICE:
 TEL: +27 (0)11 699-2400, FAX: +27 (0)11 704-3412 or 462-6669
 148 EPSOM AVENUE, NORTH RIDING
 P.O. BOX 506, CRAMERVIEW, 2060
 SOUTH AFRICA
 WEB: <http://www.centsys.co.za> General information e-mail: info@centsys.co.za

FOR TECHNICAL SUPPORT CONTACT:

SOUTH AFRICA

EAST RAND (011) 397-6401	PORT ELIZABETH (041) 581-6994/5
DURBAN (031) 701-9583	EAST LONDON (043) 743-4923
NELSPRUIT (013) 752-8074/5	BLOEMFONTEIN (051) 448-1714
PRETORIA (012) 362-8819/8893	KIMBERLEY (053) 832-3231
CAPE TOWN (021) 447-1295	VEREENIGING (016) 422-5667

AFRICA

ECHO-LINE, NAMIBIA Tel: (61) 220-8309
 MOLECULAR CONSULTANTS, NIGERIA Tel: 803-3123182
 SECURITY DISTRIBUTORS, ZIMBABWE Tel: (4) 795-873
 SEKANYOLYA TIMBER WORKS, UGANDA Tel: (41) 231-40

EUROPE

AUTOMATISME BATIMENT, FRANCE Tel: (1) 697-93120
 CROWN AXXESS LTD U.K. UNITED KINGDOM Tel: (1483) 450-011
 NESTOR, BELGIUM Tel: (9) 380-4020

NORTH AMERICA

BILLY GATES, CANADA Tel: (250) 334-1553

AUSTRALASIA

ABA GATES, WESTERN AUSTRALIA Tel: (8) 933-03061
 DOMINATOR SYSTEMS, NEW ZEALAND Tel: (3) 384-5145
 ICBT, VICTORIA Tel: (3) 933-54213
 ROTECH, QUEENSLAND Tel: (7) 326-47330
 SA GATES, SOUTHERN AUSTRALIA Tel: (8) 826-64235
 SECURITE DU PACIFIQUE, NEW CALEDONIA Tel: 283-760

INDIAN OCEAN

SECULOGIX LTD, MAURITIUS Tel: 467-8509
 SECURITE AUTOMATISMES REUNION, REUNION Tel: 280-368

ASIA & PACIFIC

VAST VIDEO, MALAYSIA Tel: (3) 214-34931
 BLT ASSOCIATES, THAILAND Tel: (2) 691-6793

SupaSlider

INSTALLATION MANUAL

Latest Revision: 15.03.2004
 Document Ref.: 0005.D.01.0001_4



Table of Contents

INTRODUCTION	Page 2
BASIC KIT	Page 2
RECOMMENDED TOOLS	Page 3
SITE PREPARATION	Page 3
TABLE 1 - CABLE REQUIREMENTS	Page 4
POSITIONING OF FOUNDATION PLATE	Page 5 - 7
MOUNTING OF RACK OR CHAIN	Page 8 - 10
MOUNTING LIMIT SWITCH STRIKERS	Page 10 - 12
ELECTRICAL CONNECTIONS	Page 13 - 22
COMMISSIONING	Page 23 - 25
COLLISION SENSING ADJUSTMENT	Page 26

Introduction

A CENTURION GATE AUTOMATION system is a quality product designed to give many years of trouble free service.

This MANUAL has been compiled to assist you, the customer, with a trouble free

PLEASE READ THE INSTRUCTIONS CAREFULLY

Basic Kit

The sliding gate kit comprises of one or more components shown in the identification list below.

<p>GEARBOX</p> <p>GEARBOX COVER</p> <p>GEARBOX CASING</p> <p>HINGE PIN</p> <p>GEARBOX BASE PLATE</p> <p>FOUNDATION PLATE</p>		<p>RACK & ATTACHMENTS</p> <p>MACHINED STEEL RACK 12mm</p> <p>PUNCHED & RIVETED STEEL RACK 10mm</p> <p>NYLON RACK 25mm</p> <p>LIMIT SWITCH STRIKER PLATE FOR STEEL RACK</p> <p>LIMIT SWITCH STRIKER PLATE FOR NYLON RACK</p> <p>25 x 25 RACK ANGLE SUPPORT BRACKET</p>	
<p>FASTENERS</p> <p>PADLOCK</p> <p>M12 NUT(S)</p> <p>M12 WASHER(S)</p>		<p>CHAIN & ATTACHMENTS</p> <p>CHAIN TENSIONER PLATE</p> <p>M12 x 85mm LONG CHAIN TENSIONER PIN</p> <p>CHAIN - 4m or 5m LENGTHS</p> <p>MASTER LINK(S)</p> <p>LIMIT SWITCH STRIKER PLATE FOR CHAIN</p> <p>CHAIN TENSIONER END BLOCK</p>	
<p>BATTERIES</p> <p>35AH BATTERY</p> <p>65AH BATTERY</p>		<p>ELECTRONICS</p> <p>STANDARD CHARGER</p> <p>PLUG IN TRANSFORMER TRANSFORMER</p> <p>CP87 SINGLE CONTROLLER</p> <p>CP77 CONTROLLER</p>	
<p>ENCLOSURES (OPTIONAL)</p> <p>CP7 ENCLOSURE SHOWN WITH CHARGER TRANSFORMER</p> <p>CP6 BATTERY ENCLOSURE</p>			

Collision Sensing Adjustment

ADJUST SETTING(S) SUCH THAT GATE(S) WILL OPEN AND CLOSE RELIABLY, BUT NOT CAUSE DAMAGE TO PERSONS OR OBJECTS IN THE PATH OF THE GATE.

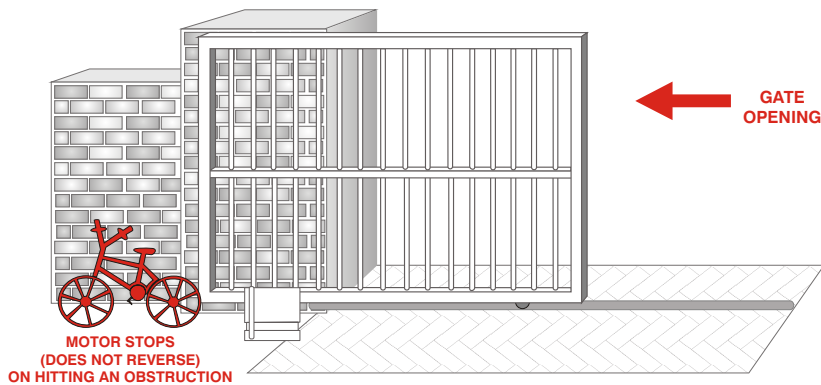
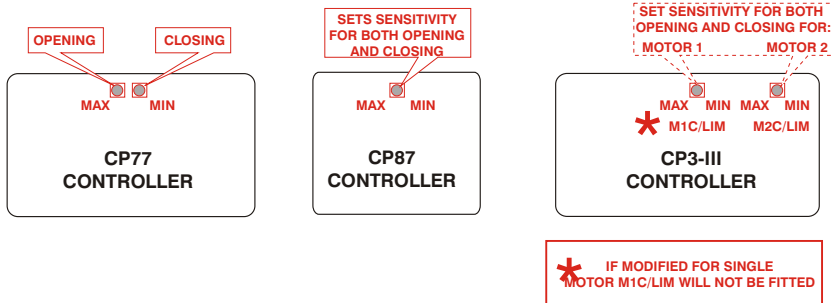
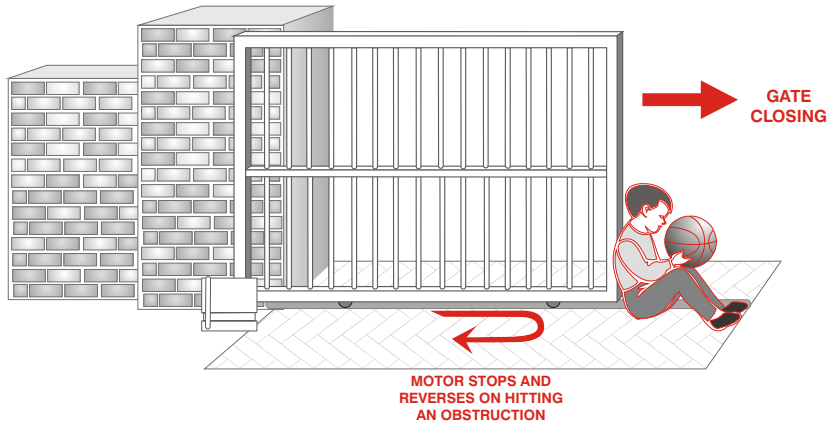

Recommended Tools

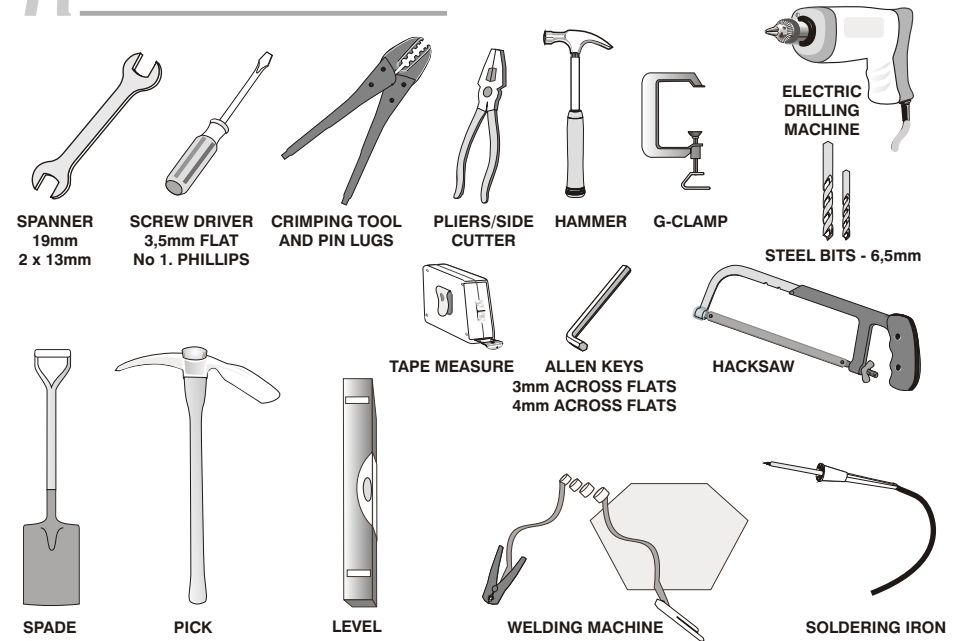

SITE PREPARATION

CHECK:

- DIMENSIONS
- MUNICIPAL BYLAWS
- WATER, SEWERAGE, ELECTRICAL CABLES

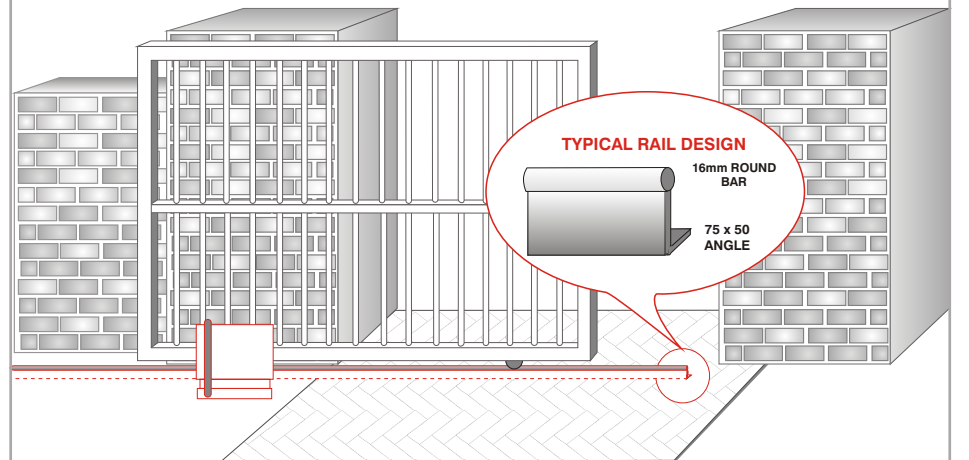

Cable Requirements

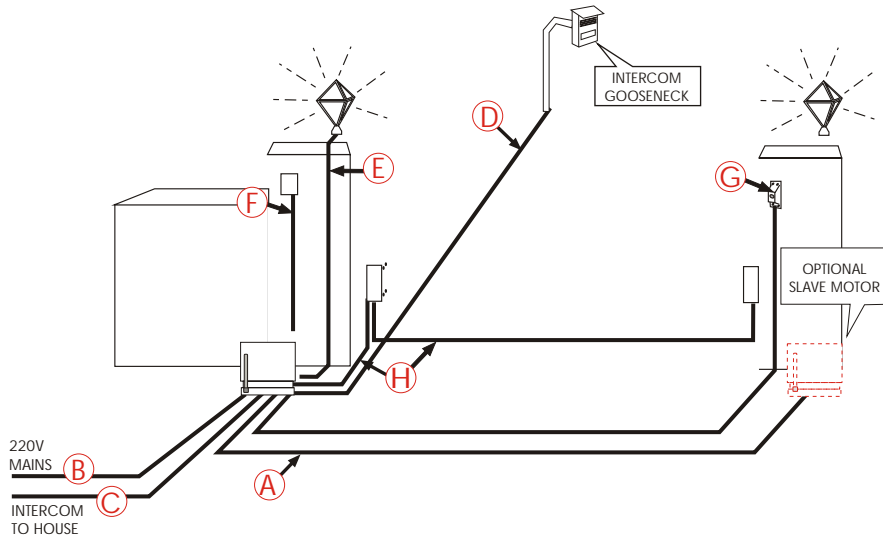

TABLE 1

NO	DESCRIPTION	NO OF CORES	SIZE mm ²	OPTIONAL	* CABLE TYPE
A	SLAVE MOTOR (MOTOR) and SLAVE MOTOR (LIMIT SWITCH)	2 3	2,5 0,2	X X	G.P. IN CONDUIT OR NORSK INTERCOM/CABTYRE/ G.P. IN CONDUIT
≠ B	EITHER: 220V AC SUPPLY CABLE OR: 15V AC TRANSFORMER SECONDARY	2 + E 2 + E	0,5 1,5		NORSK IN CONDUIT OR S.W.A. 3 CORE CABTYRE IN CONDUIT
≠ C	INTERCOM IN HOUSE & STATUS SIGNALLING	n1 + 6	0,2		INTERCOM IN CONDUIT
D	INTERCOM - GEARBOX TO GOOSENECK	n2	0,2		INTERCOM IN CONDUIT
E	PILLAR LIGHTS	2 + E	0,5	X	NORSK IN CONDUIT OR S.W.A.
F	REMOTE RECEIVER	3	0,2	X	INTERCOM/CABTYRE/ G.P. IN CONDUIT
G	PEDESTRIAN KEYSWITCH	2	0,2	X	INTERCOM/CABTYRE/ G.P. IN CONDUIT
H	INFRA RED BEAM	3	0,2	X	INTERCOM/CABTYRE/ G.P. IN CONDUIT
I	SOLAR PANEL (not shown)	2	1,5	X	CABTYRE OR G.P. IN CONDUIT

* = CABLE TYPE MINIMUM RECOMANDATION

S.W.A. = STEEL WIRE ARMoured

G.P. = GENERAL PURPOSE HOUSE WIRING OR PANEL FLEX

n1 = CONSULT INTERCOM SUPPLIER FOR REQUIRED NO. OF CORES

n2 = CONSULT INTERCOM SUPPLIER FOR REQUIRED NO. OF CORES

≠ = FOR OPTIMUM LIGHTNING PROTECTION USE SCREENED CABLE EARTHED AT BOTH ENDS

Commissioning cont'd

MOTOR AND LIMIT SWITCH POLARITY SELECTIONS

- MAKE SURE MOTOR IS DISENGAGED FROM GATE i.e. IN MANUAL MODE.
- DECIDE IF MOTOR IS MOUNTED ON RHS or LHS OF GATE (SEE FIG 1a or FIG 1b).
- TRIGGER CONTROL CARD TO RUN MOTOR(S)

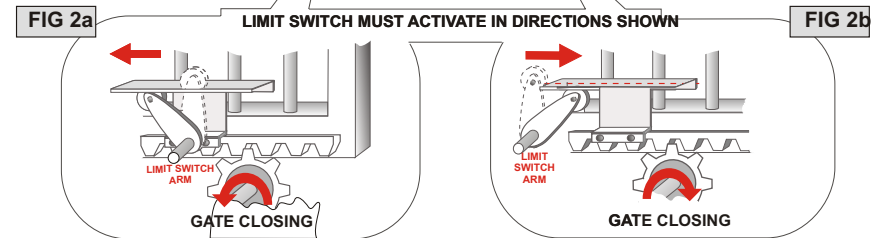
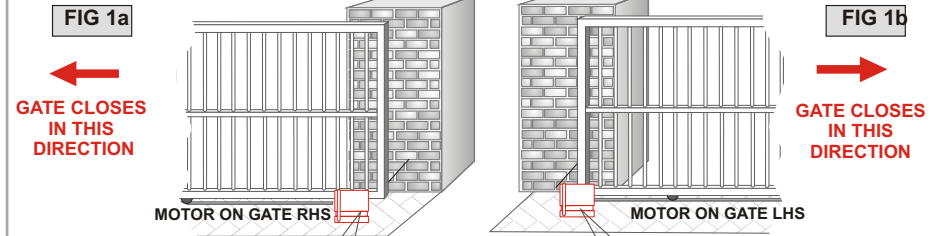

- FIG 3
- USE STATUS LED ON CONTROL CARD TO
 - DETERMINE CORRECT MOTOR

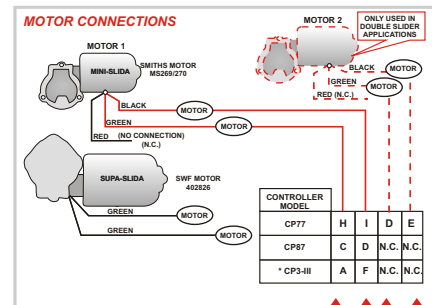
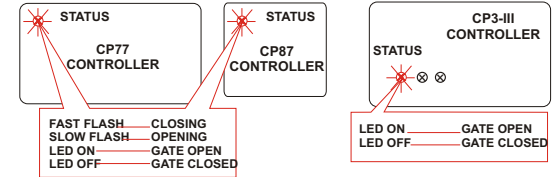

FIG 4 SWOP THESE WIRES TO REVERSE MOTOR DIRECTION

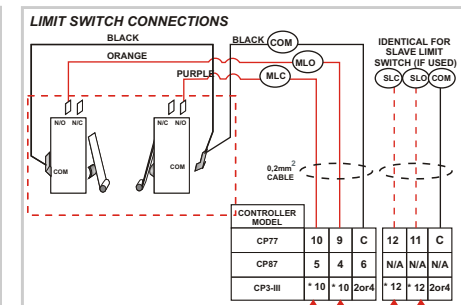
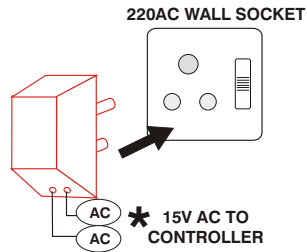

FIG 5 SWOP LIMIT SWITCH WIRES IF MOTOR DOES NOT SHUT OFF

APPLYING MAINS POWER

OPTION 1



OR

OPTION 2

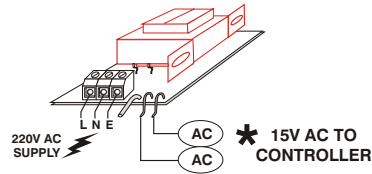

* SEE PAGE 21 FOR TRANSFORMER CONNECTIONS

- APPLY 220V AC POWER
- CHECK POWER ON INDICATION

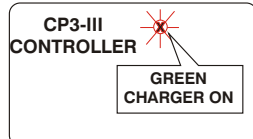
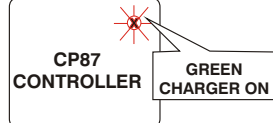
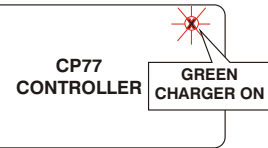

CONNECTING BATTERY

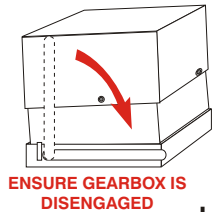

- USE MANUAL RELEASE DISCONNECT LEVER TO DISENGAGE MOTOR PINION FROM RACK OR CHAIN.
- CONNECT BATTERY

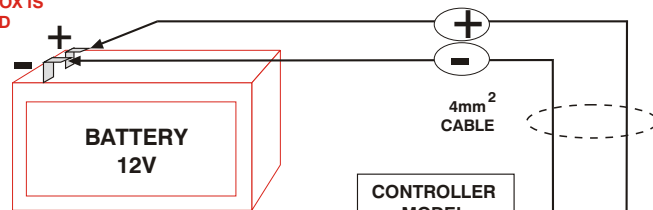

CONTROLLER MODEL	F	G
CP77	F	G
CP87	A	B
CP3-III	C	D

Positioning of Foundation Plate

STEP 1

- LOCATE CENTRELINE FOR HOLE AND FOUNDATION PLATE AS SHOWN IN TABLE BELOW.
- DIG HOLE FOR FOUNDATION PLATE APPROXIMATELY 400 x 400 x 300mm.

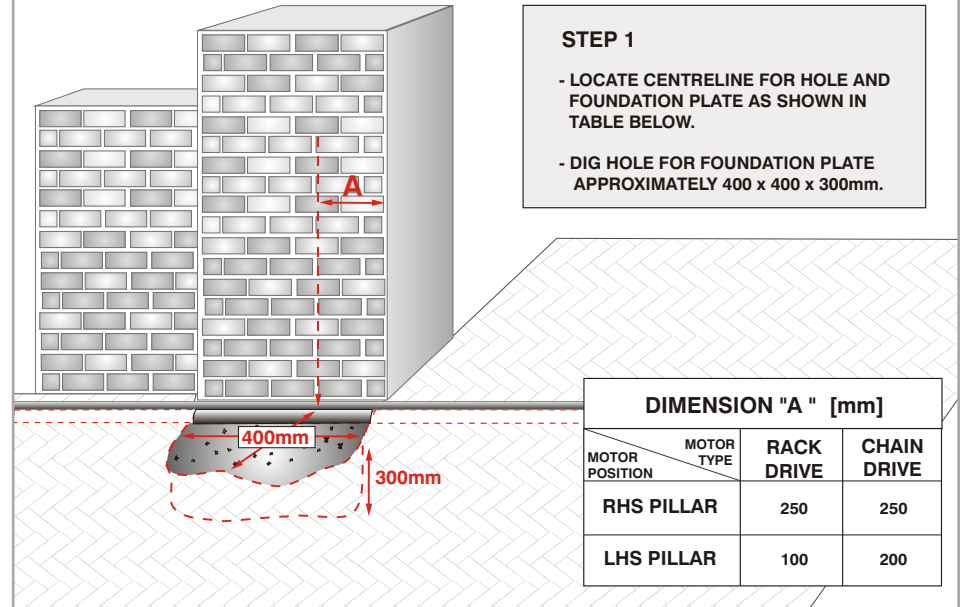

DIMENSION "A" [mm]

MOTOR POSITION	MOTOR TYPE	RACK DRIVE	CHAIN DRIVE
RHS PILLAR		250	250
LHS PILLAR		100	200

MOUNTING FOUNDATION PLATE FOR RACK SLIDER

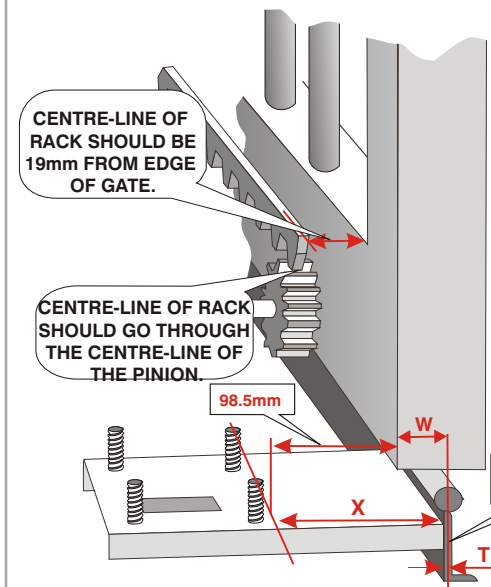

STEP 2a (SEE STEP 2b IF CHAIN SLIDER IS BEING INSTALLED)

- LOCATE THE FOUNDATION PLATE SUCH THAT THE DISTANCE FROM THE SIDE OF THE GATE TO THE CENTRE-LINE OF THE HOLDING DOWN STUDS IS 98.5mm.

IF NECESSARY, CUT THE PLATE TO SIZE. eg IN THE DRAWING SHOWN, THE PLATE WOULD BE CUT SUCH THAT $X = 98.5 + W - T$ WHERE W=HALF THE

MOUNTING FOUNDATION PLATE FOR CHAIN DRIVE SLIDER.

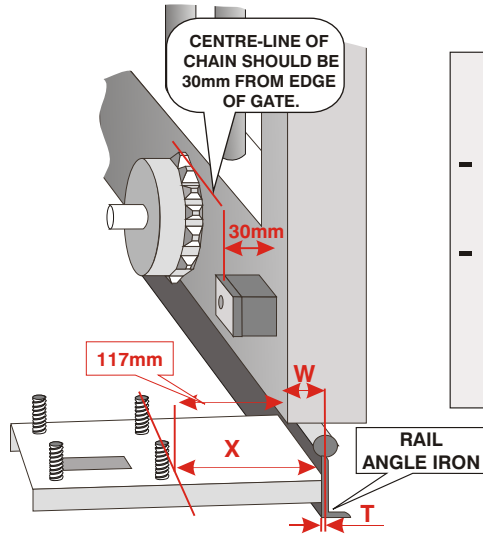

STEP 2(b) (SEE STEP 2a IF RACK SLIDER IS BEING INSTALLED)

- LOCATE THE FOUNDATION PLATE SUCH THAT THE DISTANCE FROM THE SIDE OF THE GATE TO THE CENTRE-LINE OF THE HOLDING DOWN STUDS IS 117mm.

IF NECESSARY, CUT THE PLATE TO SIZE. eg IN THE DRAWING SHOWN, THE PLATE WOULD BE CUT SUCH THAT $X=117+W-T$ WHERE W =HALF THE GATE WIDTH AND T = HALF THE

STEP 3 AND 4

- WELD FOUNDATION PLATE TO RAIL
- FIT M12 NUTS AND WASHERS

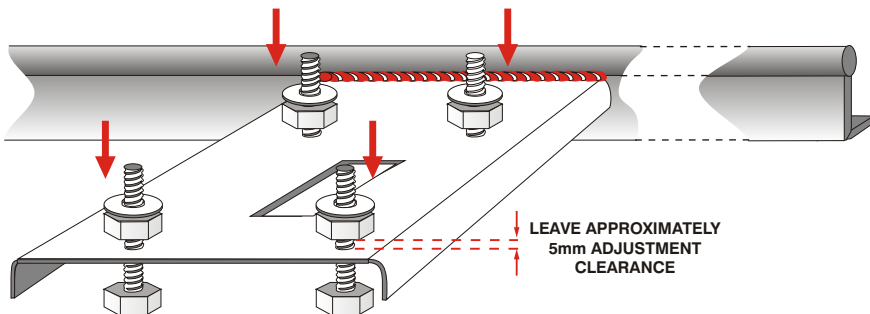

CONTROL CARD SETUP

CP77

LED	GATE STATUS
LED OFF	GATE CLOSED
LED ON	GATE OPEN
FAST FLASH	CLOSING
SLOW FLASH	OPENING
★ 2 FLASH/2 SECS	MAINS FAILURE
3 FLASH/2 SECS	BATTERY LOW

★ NOTE: MAINS FAILURE DOES NOT APPLY TO CP87 CONTROL CARD.

1 2 3 4

AUTOCLOSE TIMER 5 SECS 45 SECS

COLLISION SENSITIVITY OPEN CLOSE

GREEN POWER ON LED (ON WITH MAINS POWER PRESENT)

GATE STATUS LED (RED)

CP77 AND CP87

SWITCH NO	1	2	3	4	DESCRIPTION OF OPERATION (MODE)
1	0	0	0	0	SINGLE MOTOR SYSTEM WITHOUT AUTOCLOSE
1	0	0	0	0	SINGLE MOTOR SYSTEM WITH AUTOCLOSE
0	0	0	0	1	DOUBLE MOTOR SYSTEM WITHOUT AUTOCLOSE
1	0	0	0	1	DOUBLE MOTOR SYSTEM WITH AUTOCLOSE
0	1	0	0	0	CONDOMINIUM MODE (SINGLE MOTOR)
0	1	0	1	0	PIRAC MODE (SINGLE MOTOR)
1	1	0	0	0	CONDOMINIUM MODE (DOUBLE MOTOR)
1	1	0	1	0	PIRAC MODE (DOUBLE MOTOR)
0	0	1	0	0	LINEAR MOTOR(S) WITHOUT AUTOCLOSE
1	0	1	0	0	LINEAR MOTOR(S) WITH AUTOCLOSE

CP77 V1.X

1 (SEE NOTE) 16

NOTE: LIMIT SWITCH LEADS ONLY ON VERSION 1.1 CARDS AND ABOVE

CP87

COLLISION SENSITIVITY MAX MIN

AUTOCLOSE "ON"

AUTOCLOSE "OFF"

GATE STATUS LED (RED)

GREEN POWER ON LED (ON WITH MAINS POWER PRESENT)

1 9

COMMISSIONING INSTRUCTIONS

- IDENTIFY STATUS LED WHICH WILL GIVE INFORMATION ON GATE STATUS (e.g. WHETHER GATE SHOULD BE OPEN OR CLOSED).
- SELECT DIP SWITCH SETTINGS TO GIVE REQUIRED MODE OF OPERATION (CP77 ONLY).
- SELECT "AUTOCLOSE" IF REQUIRED (e.g. USING SW1 ON CP77, JUMPER ON CP87, OR WIRE LINK BETWEEN TERMINAL 4 & 5 ON CP3-III CARD).
- SET AUTOCLOSE TIMER POTENTIOMETERS TO MINIMUM INITIALLY AND ADJUST TIME TO SUIT AFTER COMMISSIONING.

CP3-III

GREEN POWER ON LED (ON WITH MAINS POWER PRESENT)

8 Sec 40Sec 3 Sec 30Sec

MOTOR CUTOUT TIMER AUTO-CLOSE TIMER

MOTOR 1 COLLISION SENSITIVITY MOTOR 2 COLLISION SENSITIVITY

(LINK TERMINAL 4 TO 5 FOR AUTOCLOSE TO FUNCTION)

GATE STATUS LED (RED)

LED	GATE STATUS
LED OFF	GATE CLOSED
LED ON	GATE OPEN
FAST FLASHING MOVING	

1 4 5 16

AUTOCLOSE LINK

A B C D E F G H

RADIO CONNECTIONS - (REFER TO CENTURION FOR CODING DETAILS)

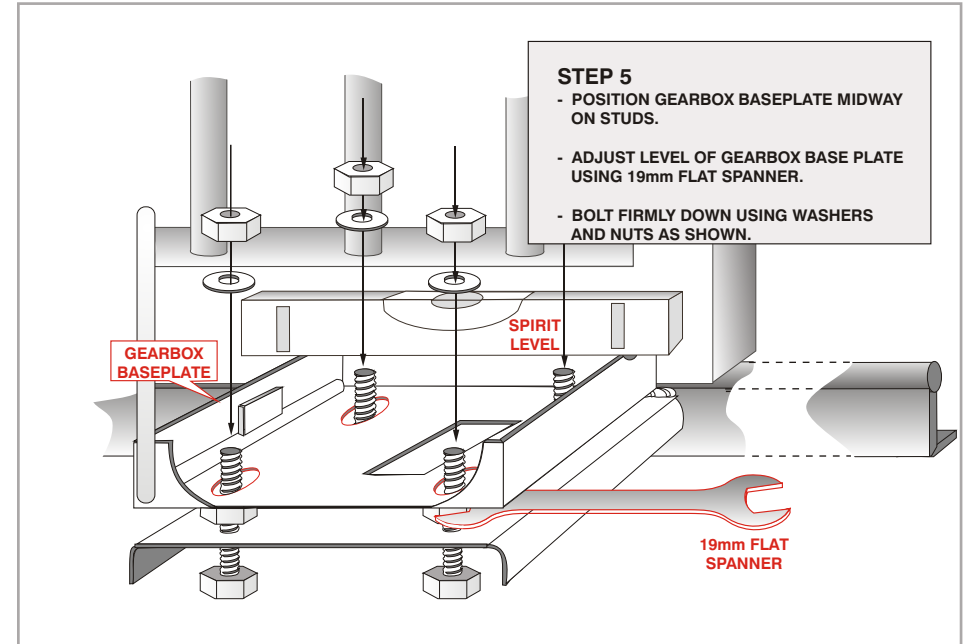
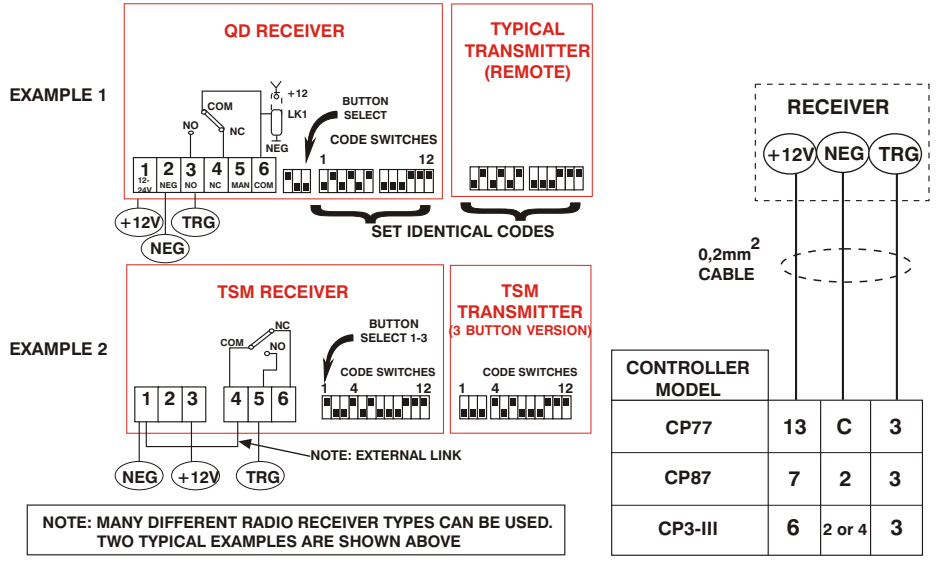

RECOMMENDED EARTHING FOR LIGHTNING PROTECTION

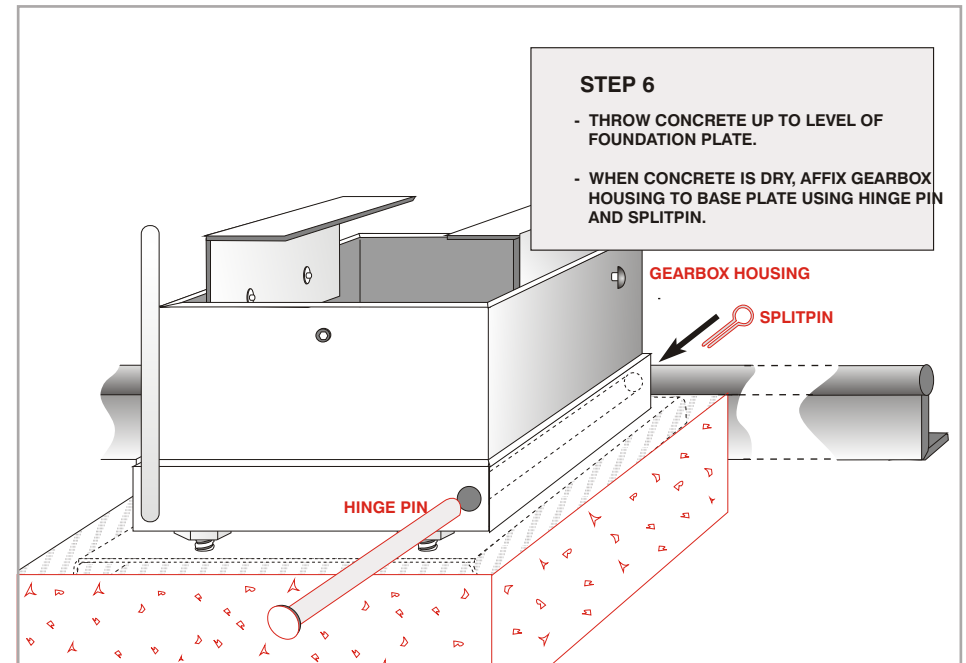
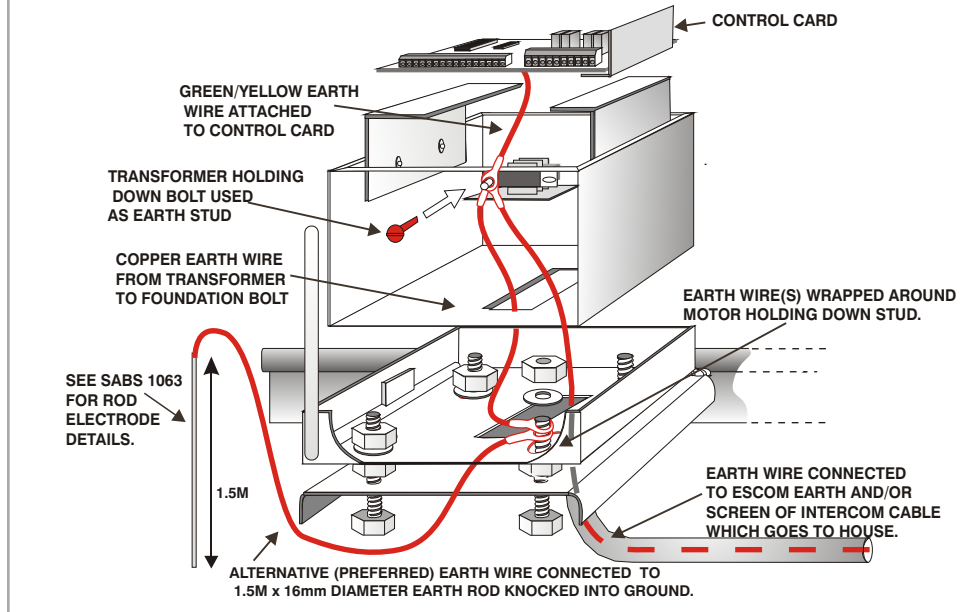

Mounting of Rack or Chain

STEEL RACK POSITIONING

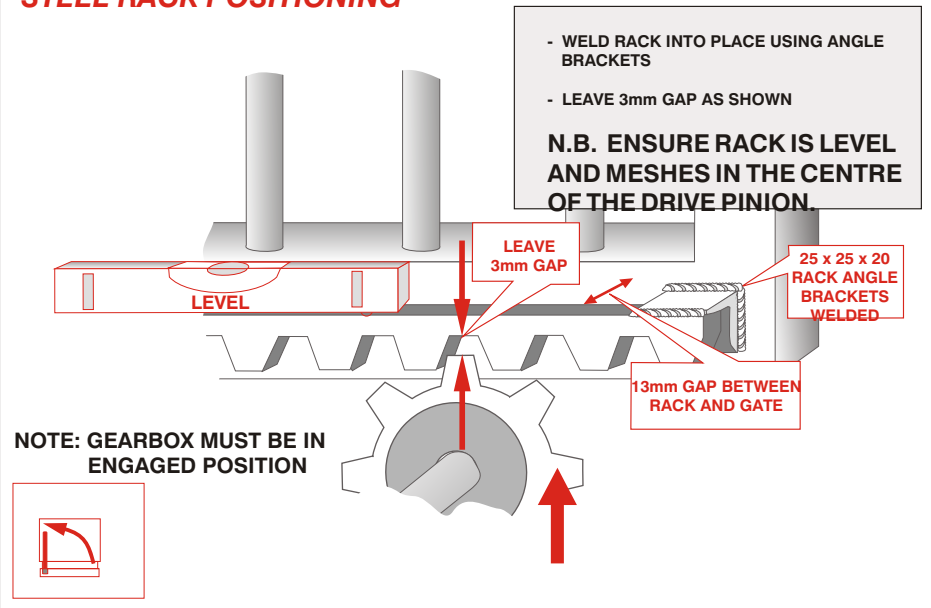

JOINING STEEL RACK

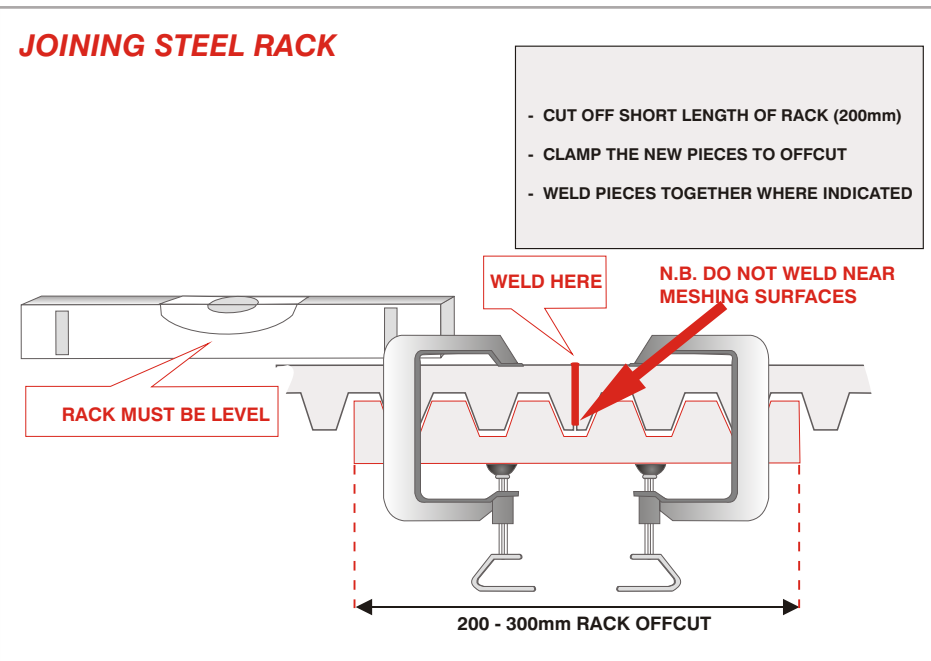

Electrical Connections cont'd

BATTERY CHARGER TRANSFORMER SUPPLY

OPTION 1 PLUG IN TRANSFORMER IN HOUSE

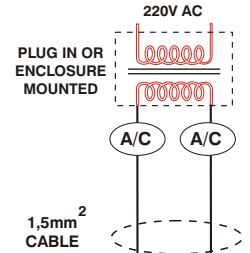
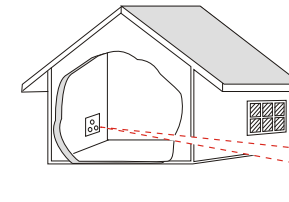

OPTION 2 ENCLOSURE MOUNTED CHARGER TRANSFORMER MOUNTED AT GATE

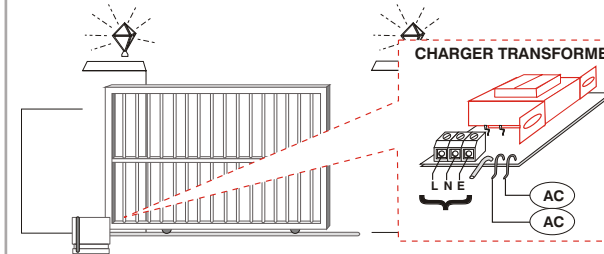

CONTROLLER MODEL	15	16
CP77	15	16
CP87	8	9
CP3-III	15	16

SOLAR PANEL



NORTH FACING SOLAR PANEL

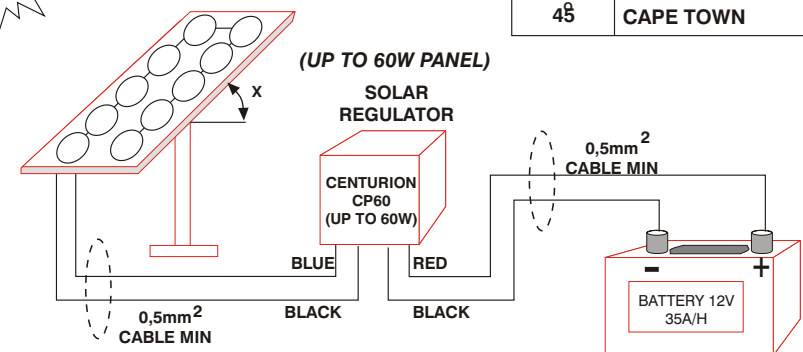

ANGLE, X°	LOCATION
30	JOHANNESBURG
40	PE & EAST LONDON
45	CAPE TOWN

NOTE: TO PREVENT THE STATUS LED ON THE CP77 CONTROLLER FROM INDICATING "MAINS FAILURE", IT IS NECESSARY TO CONNECT TERMINAL 13 TO TERMINAL 15.

PILLAR LIGHT(S)

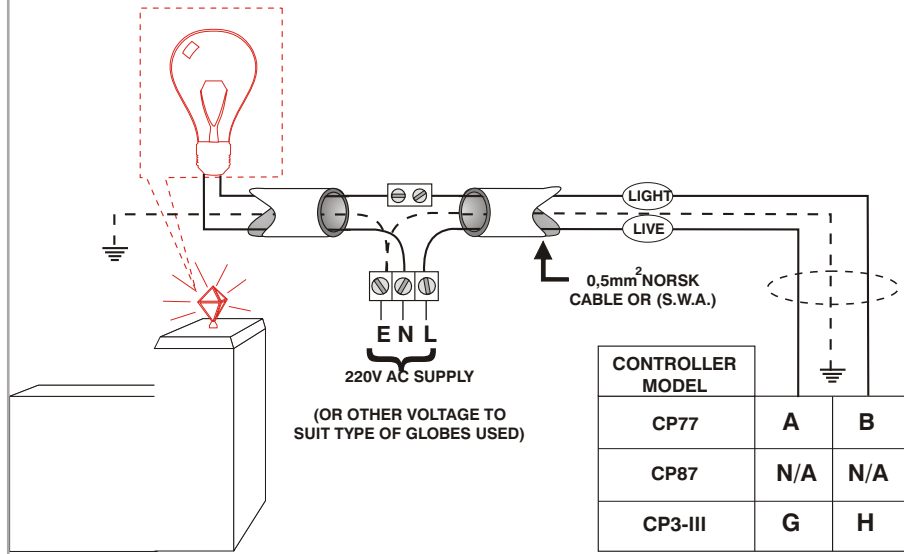

MOUNTING AND JOINING NYLON RACK

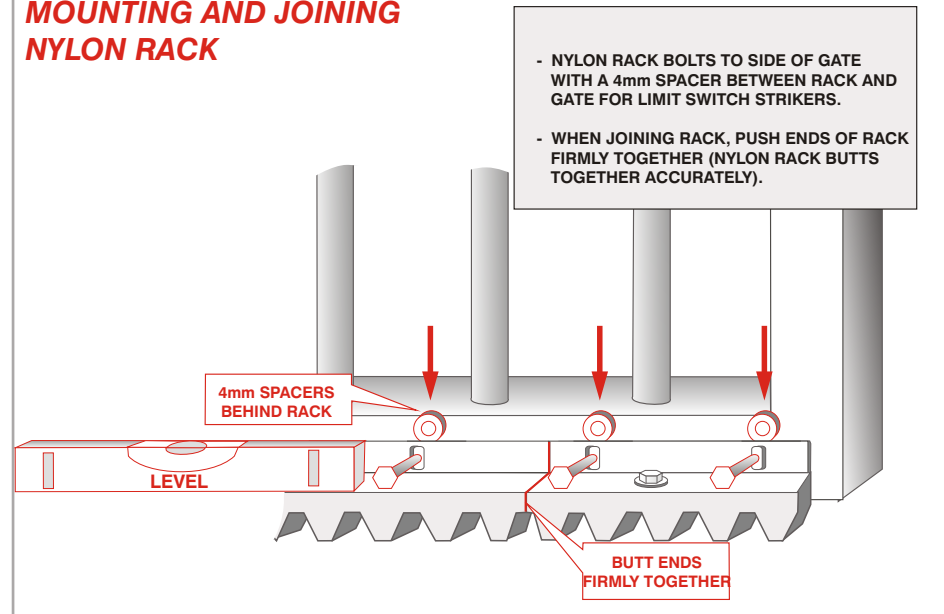

REMOTE PILLAR LIGHT CONTROL

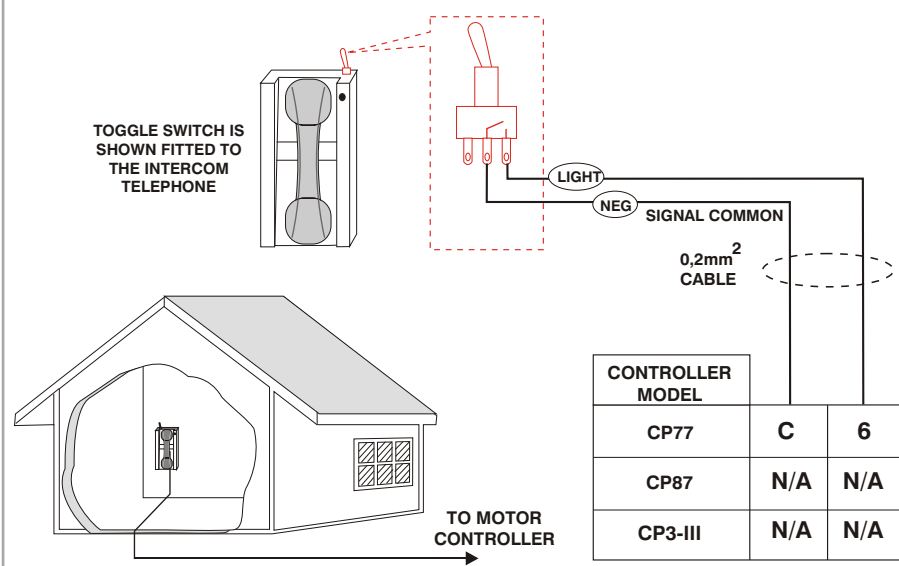

CHAIN POSITIONING

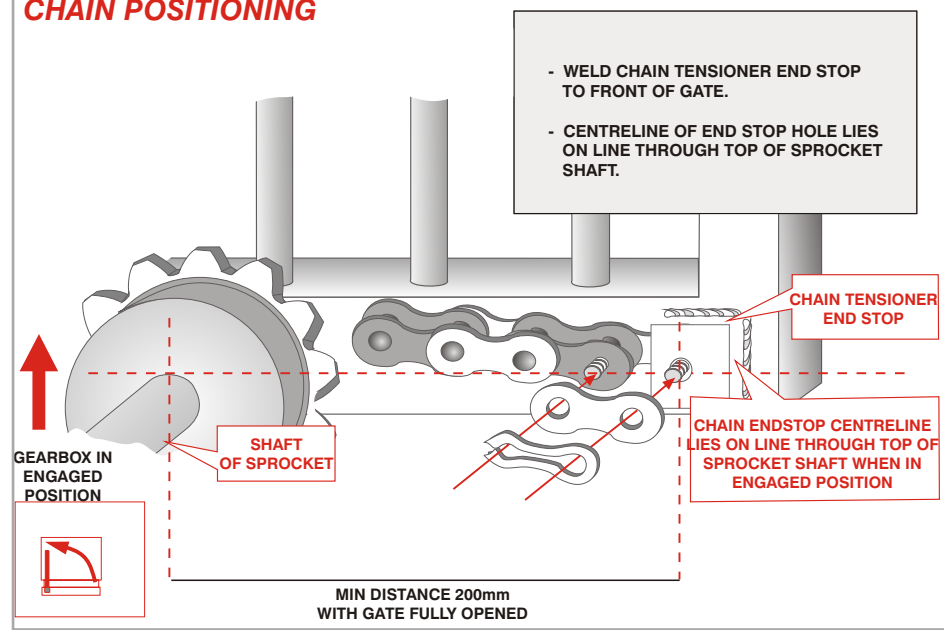

Mounting of Rack or Chain cont'd

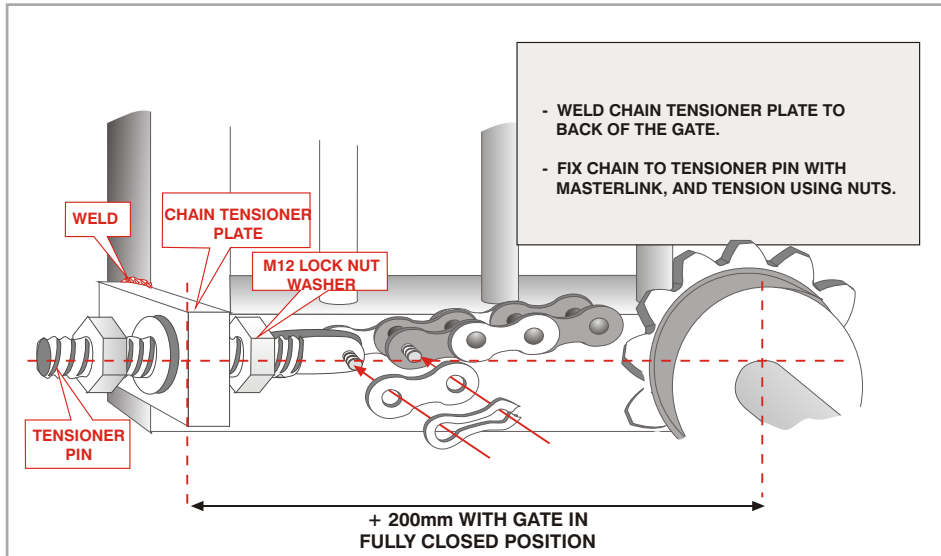

MOUNTING LIMIT SWITCH STRIKERS

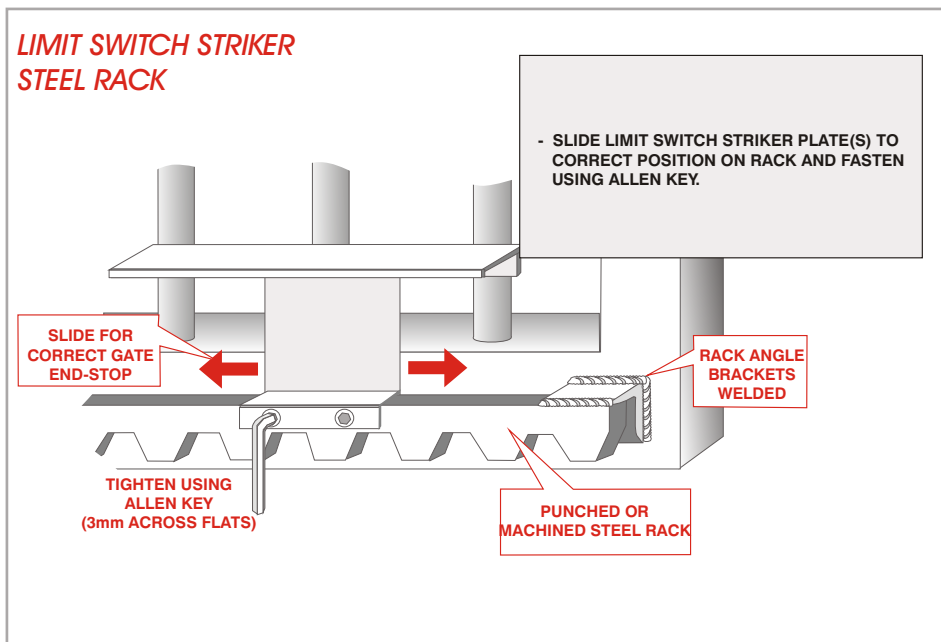

Electrical Connections cont'd

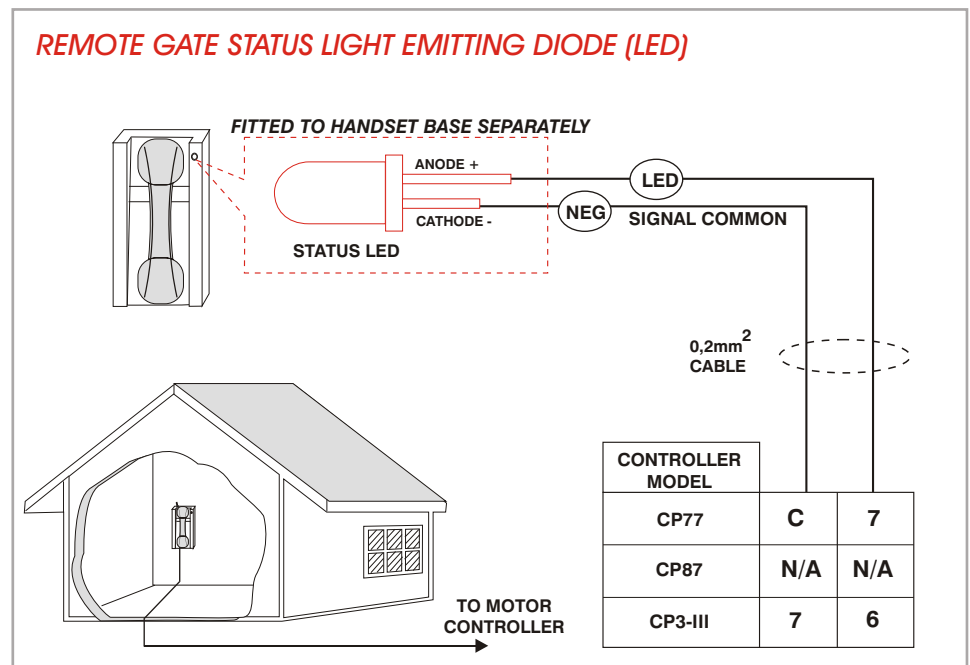
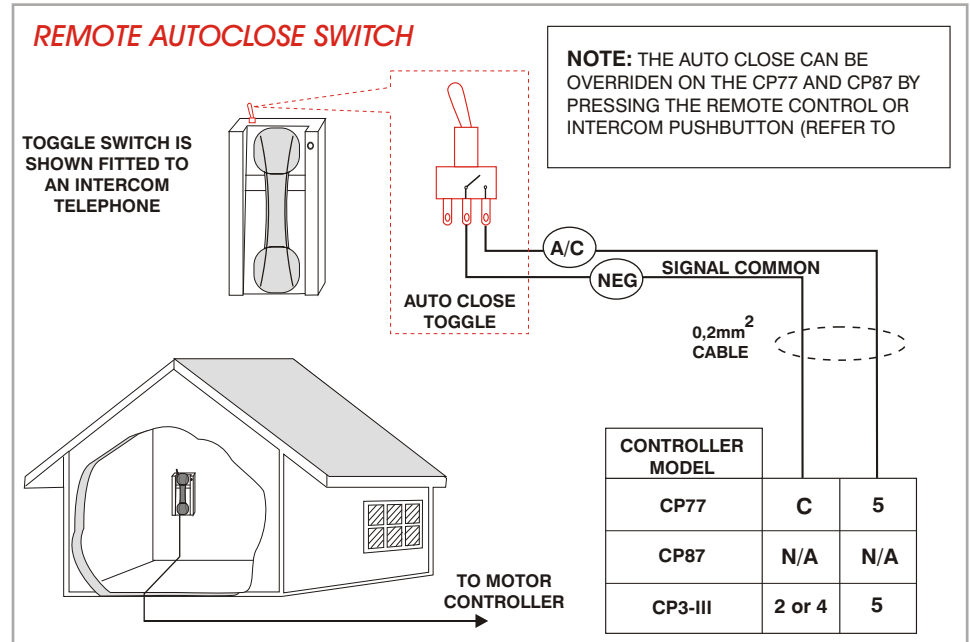

HOLIDAY LOCKOUT

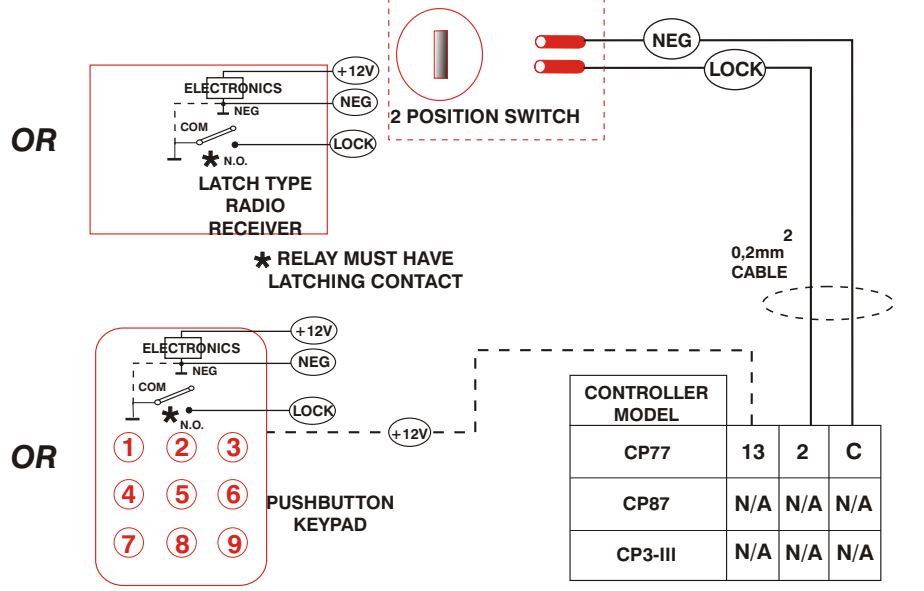

FREE EXIT LOOP - ELECTROMATIC PD132 INDUCTIVE LOOP DETECTOR IS SHOWN BELOW. MODIFY WIRING IF OTHER MAKES OF DETECTORS ARE USED.

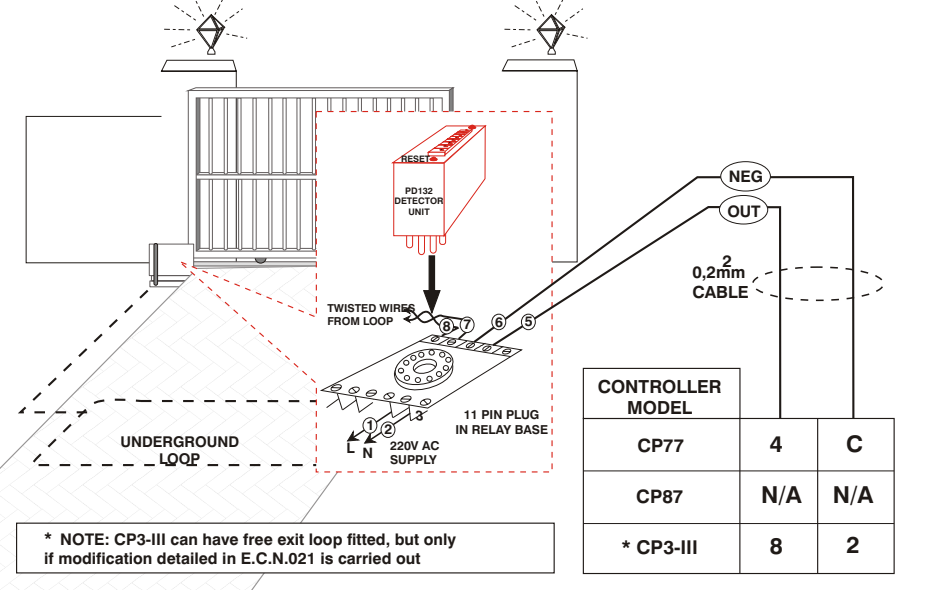

LIMIT SWITCH STRIKER NYLON RACK

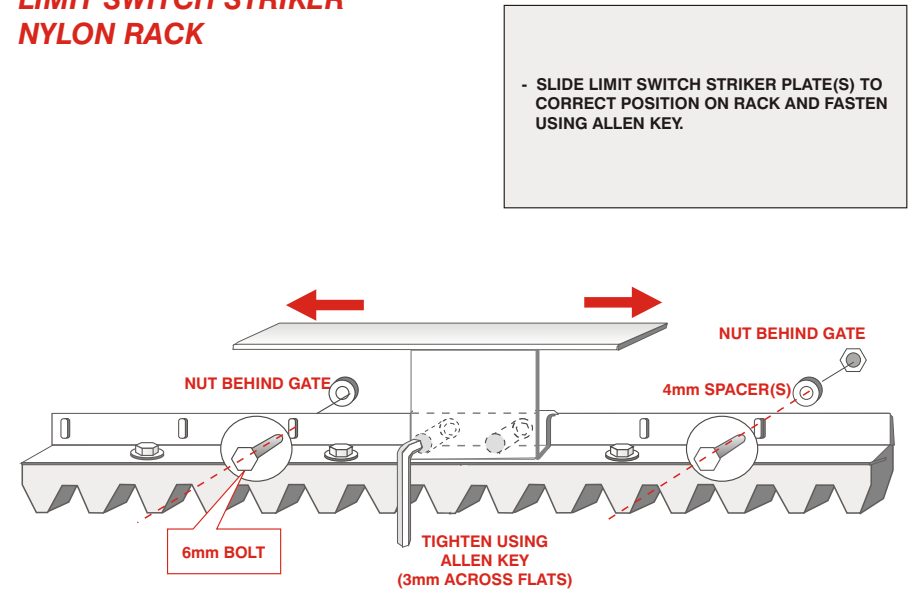

LIMIT SWITCH STRIKER CHAIN DRIVE UNITS

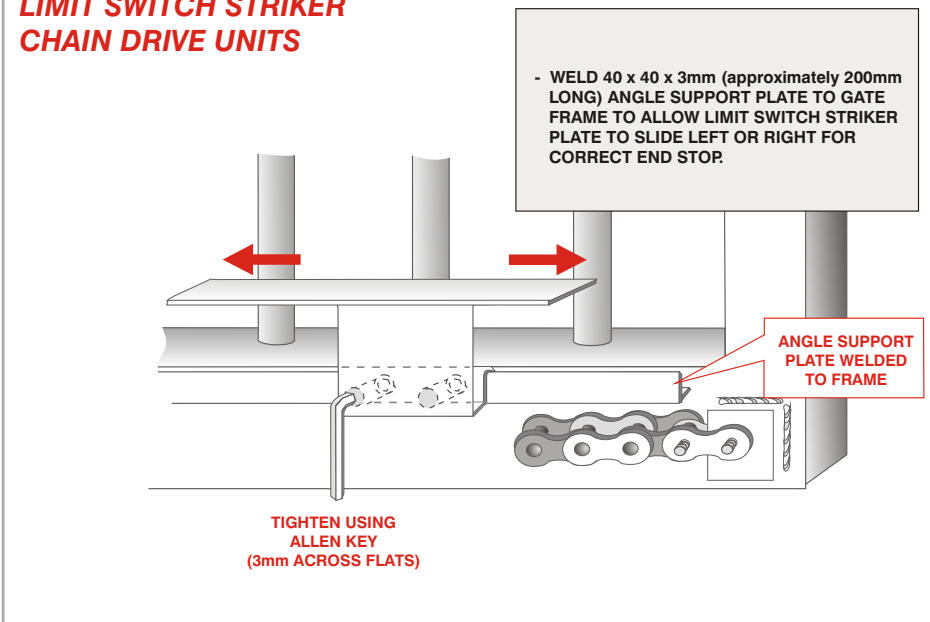

POSITIONING OF LIMIT SWITCH ARM

- ENSURE THAT LIMIT SWITCH ARM DEFLECTS BY MORE THAN 6mm.
- GATE MUST NOT BANG INTO END STOPS. LEAVE MIN 20mm CLEARANCE.

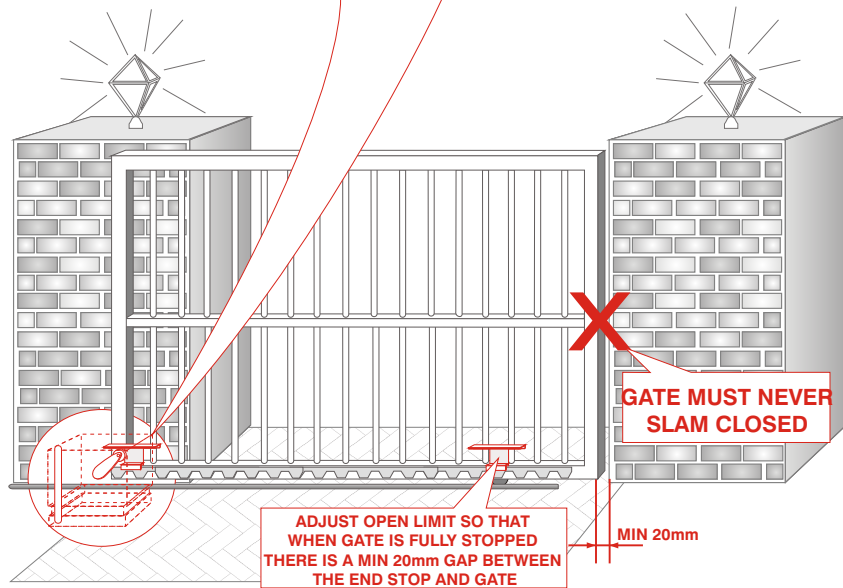
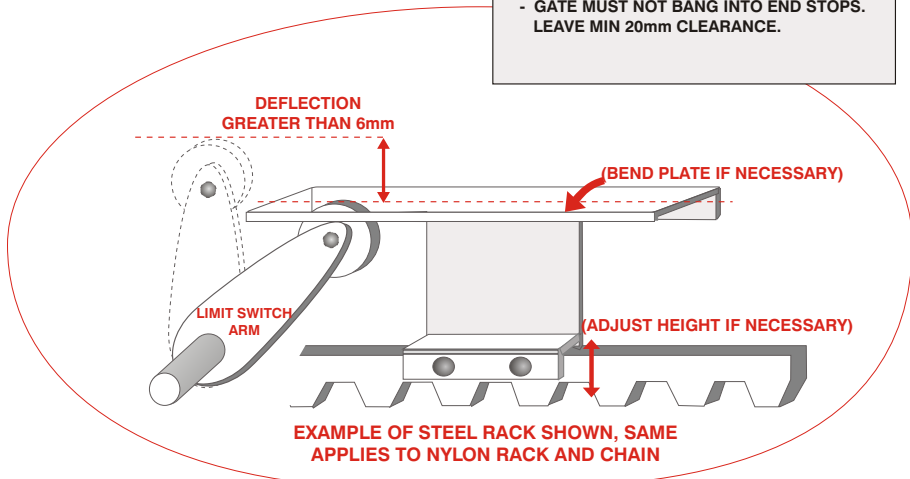

INFRA-RED BEAMS -MANY TYPES OF BEAMS ARE AVAILABLE TWO EXAMPLES ARE SHOWN BELOW

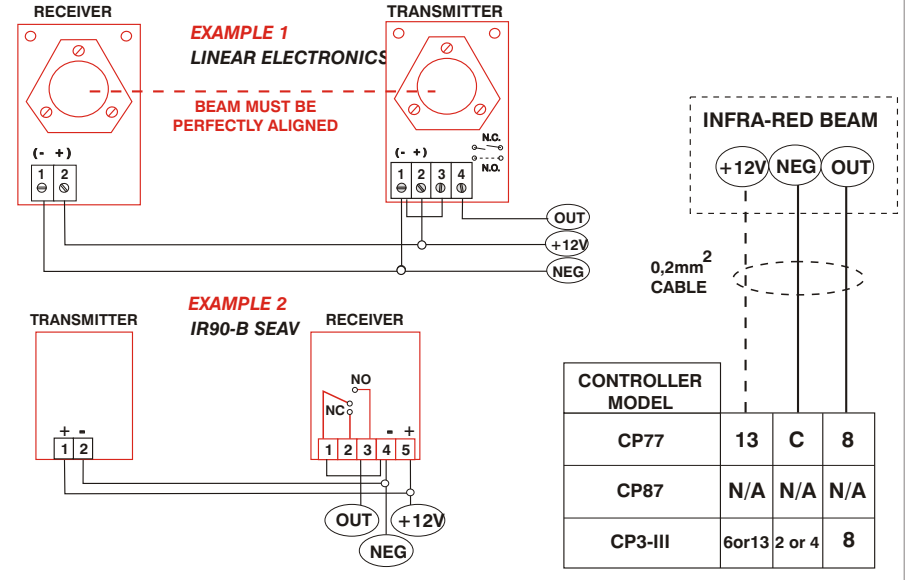

PEDESTRIAN KEYSWITCH

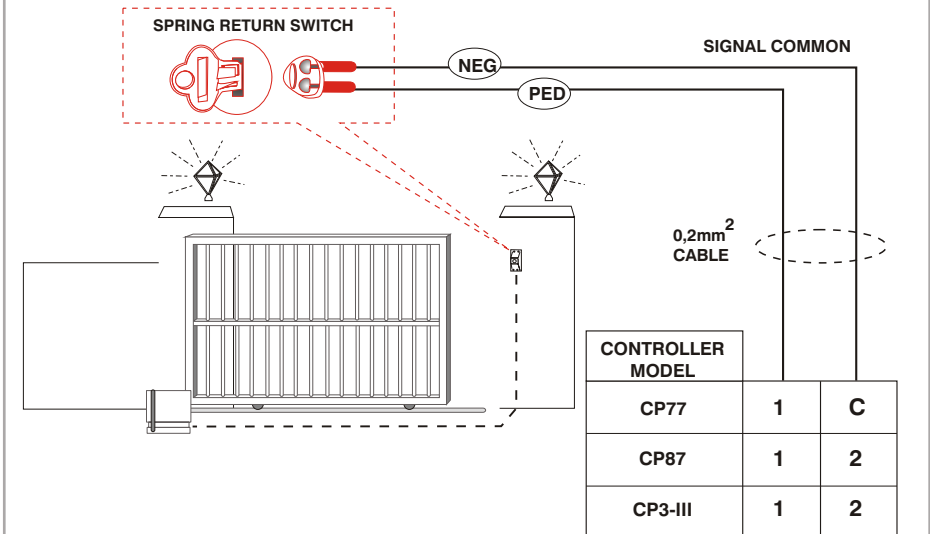

INTERCOM CONNECTIONS

NOTE:- Many different intercom types are available.
 - Only signals necessary to interface intercom to Centurion's controller are shown.

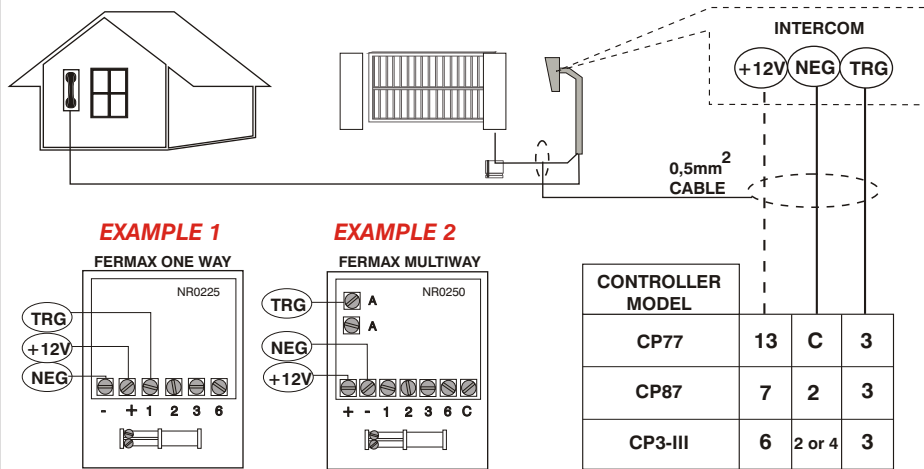

EXAMPLE 3 BPT 1 - 1 (WITH 12V DC POWER SUPPLY)

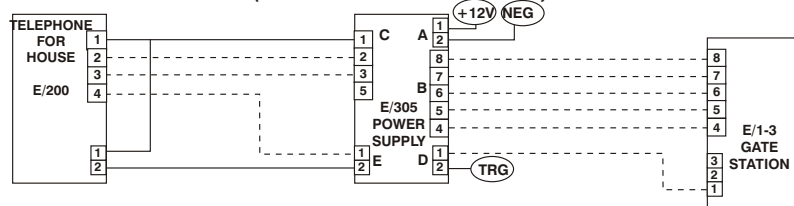

EXAMPLE 4 COMMAX 1 - 1 (12V)

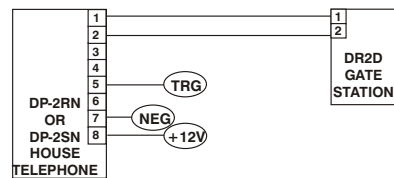

EXAMPLE 5 TYPICAL 220V AC POWERED INTERCOM

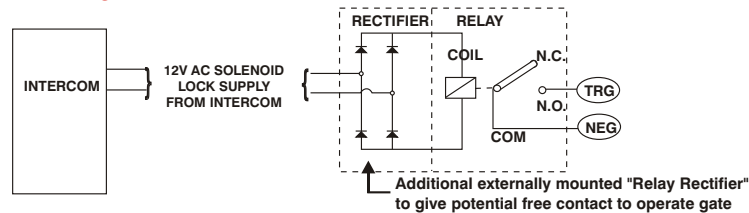

N.B.

Various controllers are available. Select the correct controller drawing from those shown below:

CONTROLLER TYPES

- 1) CP77 - DOUBLE/SINGLE SLIDING GATES WITH MULTIPLE FEATURES
- 2) CP87 - SINGLE SLIDING GATES (BASIC FEATURES ONLY)
- 3) CP3-III - OLD VERSION CONTROLLER (SUPERSEDED BY CP77)

NOTES:

CP77 CONTROLLER - DOUBLE/SINGLE SLIDER CONTROLLER WITH MULTIPLE FEATURES

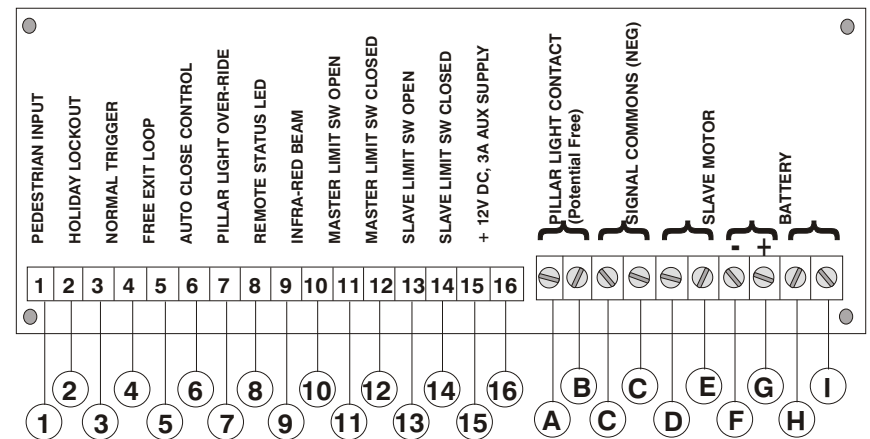

CP87 CONTROLLER - SINGLE MOTOR CONTROLLER WITH BASIC FEATURES

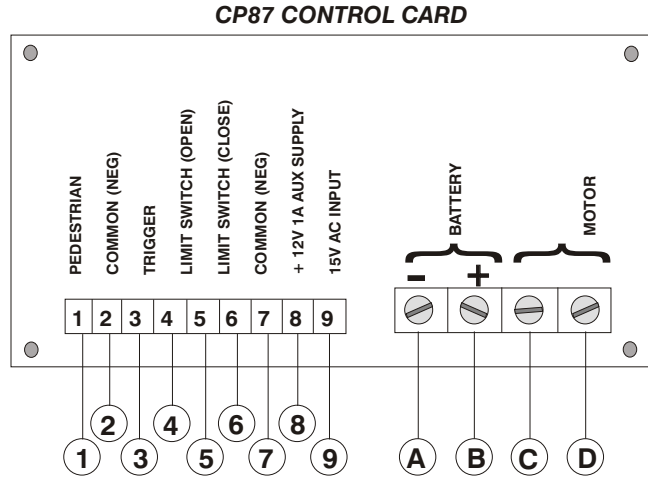

LIMIT SWITCH CONNECTIONS

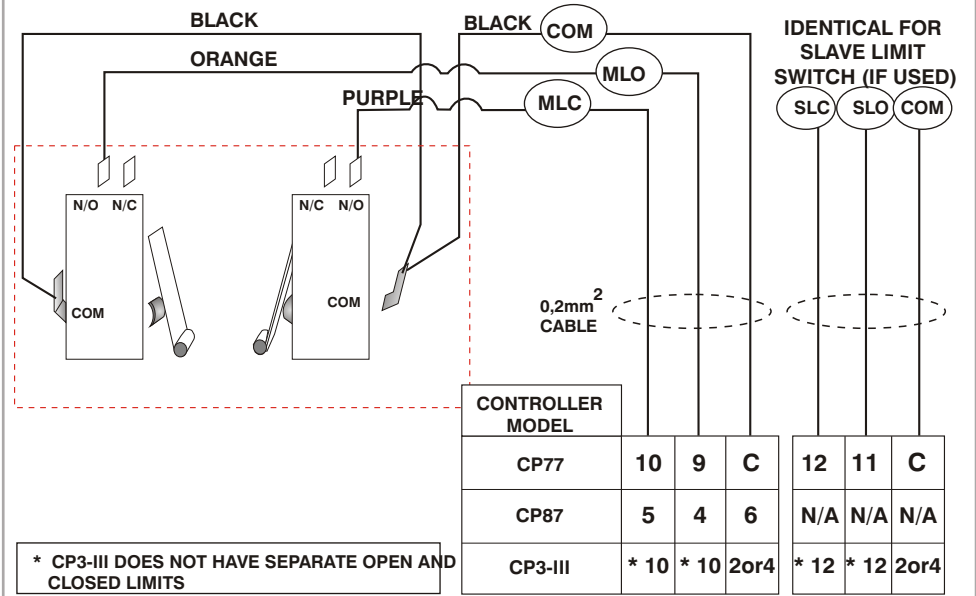

CP3-III CONTROLLER - USED ON SYSTEMS PRIOR TO AUGUST 1993 (USE CP77 FOR NEW INSTALLATIONS)

CP3-III CONTROL CARD

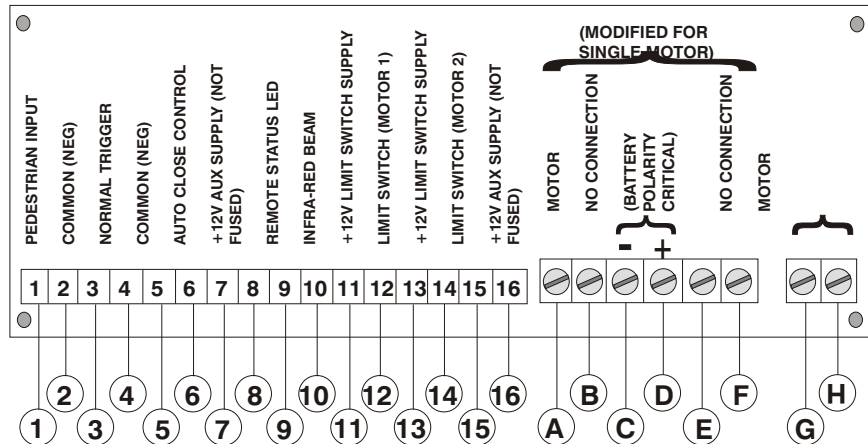

* CP3-III MODIFIED FOR SINGLE MOTOR APPLICATION (IDENTIFIED BY SINGLE SHUNT WIRE BETWEEN RELAY SETS).

MOTOR CONNECTIONS

